

# Rope Length Transmitters

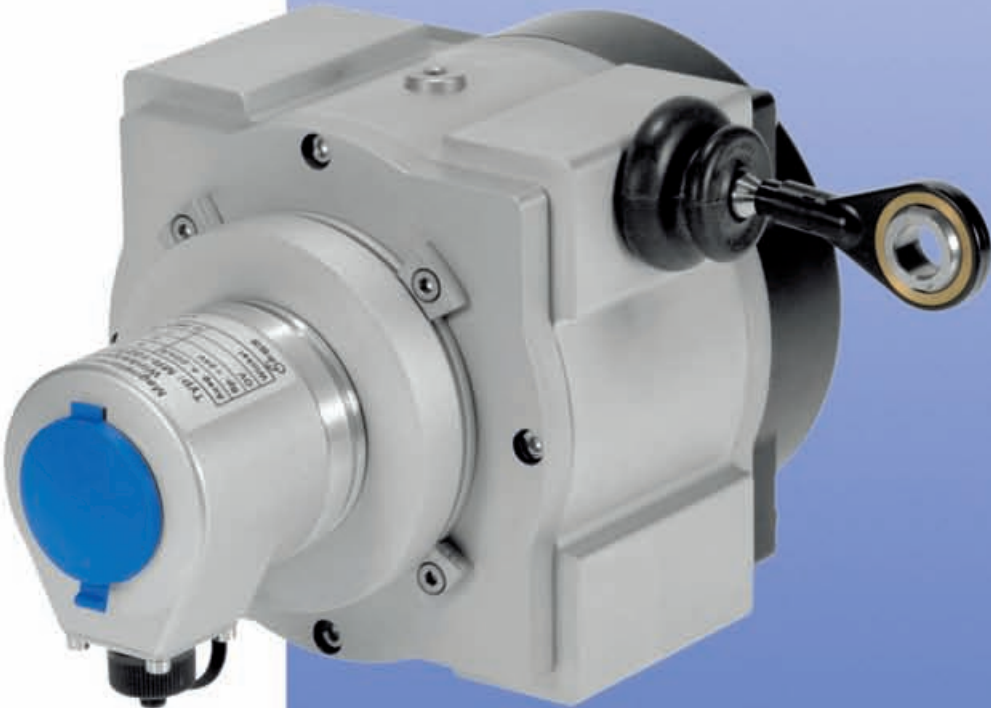

# Rope Length Transmitters

Signal converters according to the draw-wire measuring principle are preferably used for well priced and easy-to-mount positioning tasks. The product range provides 3 series with a selection of 3 sensor systems for the most different application ranges.

## ... Series

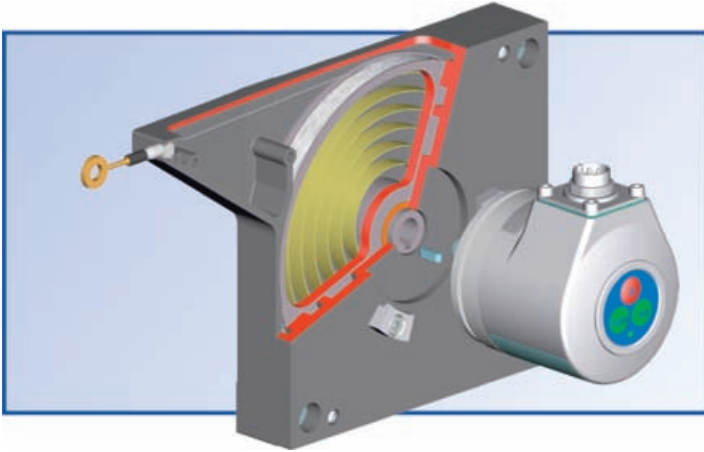

### Series SL00...

Low-cost versions

For measuring ranges from **0 - 125 mm**  
up to **0 - 5000 mm**

- Flat design
- Light-weight plastic design
- Drum bearing carried out by the shaft of the flanged encoder
- Various mounting possibilities
- Possibility to attach all encoding systems customary in trade with servo mount sizes 13 and 23

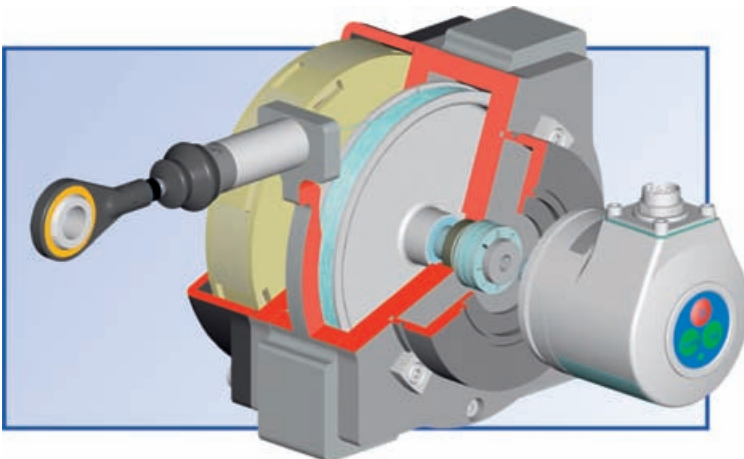

### Series SLO...

Rugged, industrial version

For measuring lengths from **0 - 1000 mm**  
up to **0 - 15000 mm**

- Rugged drum casing, material: aluminium
- Reliable wire outlet by bellows with cross role arrangement
- Low-priced option to series SL
- Possibility to attach all encoding systems customary in trade with servo mount sizes 13 and 23 via backlash compensated coupling or backlash compensated gearing

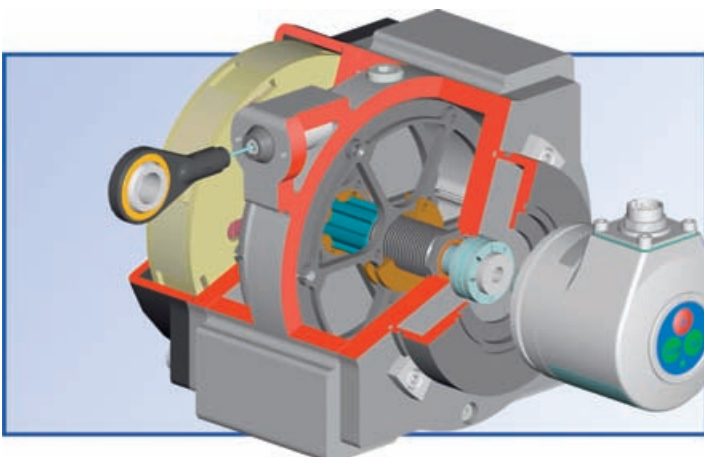

### Series SL...

Rugged, industrial version

For large measuring lengths from **0 - 1000 mm**  
up to **0 - 60000 mm**

- Patented drum drive with regard to wire withdrawal via threaded spindle
- Advanced working reliability and measuring accuracy
- Rugged drum casing, material: aluminium
- Possibility to attach all encoding systems customary in trade with servo mount sizes 13 and 23 by means of backlash compensated coupling or backlash compensated gearing

All three series contain inside a rugged plastic or aluminium casing a light-weight high precision measuring drum on which by means of an extremely stable spring pull-back mechanism one layer of a highly flexible steel wire is wound. All series are equipped with flange, coupling or measuring gear unit supports, in order to attach all encoder systems customary in trade.

## ... measuring systems

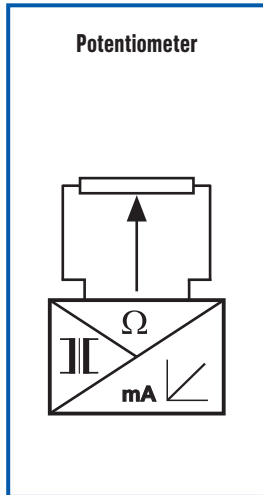

**Potentiometric transmitter systems** with high resolution and linearity of  $< \pm 0.1\%$  are preferably used for almost every application for reasons of costs. They are available with any resistance values and signal characteristics or in connection with an integrated programmable signal converter with current or voltage output.

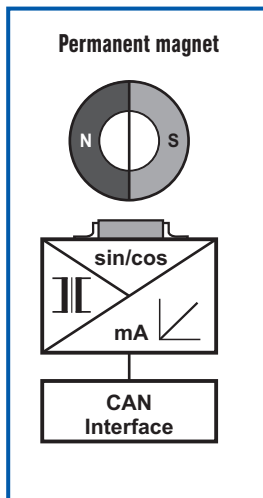

**Magnetic transmitter systems** are absolutely wear-free and reliable, even under extremely environmental conditions. They contain inside a generally closed aluminium casing of the bi-chamber design a permanent magnet, of which the magnetic field direction is output by a high precision magnetic sensor either analogue, for example 4 - 20 mA, or digital, i. e. incrementally or absolutely coded with CAN signal. Signal matching to the respective wire withdrawal is carried easily by programming keys at rear of transmitter.

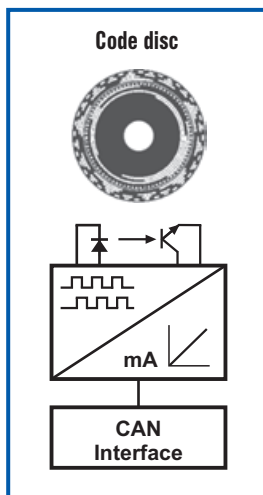

**Optoelectronic transmitter systems** are available either as incrementally or absolutely coded version. Incremental systems convert the length to be measured into a proportional pulse number with A and B track, 90° offset, for purposes of direction identification. Absolutely coded systems are available as multi-turn transmitters with a resolution of 16 bit in CAN open Standard or in user-defined data format.

## ... applications



multilevel shelving rack systems



electro overhead conveyors



mobile cranes



fork lift trucks



pressing and punching machines

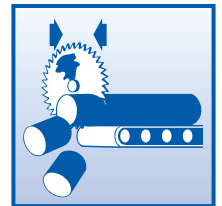

wood- and stone working machines

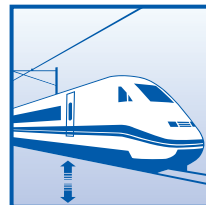

railways

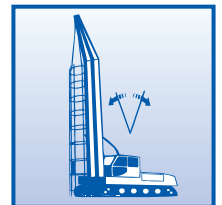

drilling equipment

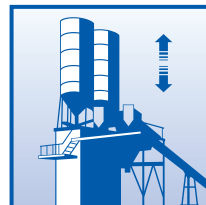

silo

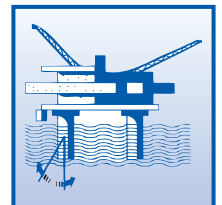

drilling platform

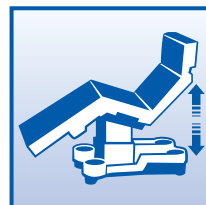

operating tables



lifting workbench

# Overview of measuring lengths of draw-wire mechanisms

Measuring length up to	SL00 125 GS 55	SL00 1250 GS 55	SL00 200 GS 80	SL00 3000 GS 80	SL00 300 GS 130	SL00 5000 GS 130	SLO 1.5 GS 55	SLO 2...3 GS 80	SLO 5 GS 130	SL 3002 GS 55	SL 3001 ... 3003 GS 80	SL 3005 ... 3030 GS 130	SL 3015 ... 3040 GS 190
125 mm	✓												
200 mm			✓										
300 mm					✓								
1000 mm											✓		
1250 mm		✓											
1500 mm							✓						
2000 mm								✓		✓	✓		
3000 mm				✓				✓			✓		
5000 mm						✓			✓			✓	
10000 mm												✓	
15000 mm												✓	✓
20000 mm												✓	✓
25000 mm												✓	✓
30000 mm												✓	✓
40000 mm													✓
50000 mm													on demand
60000 mm													on demand



For intrinsically safe applications "ex" suitable angular transmitters with signal converters are available. EG type test TÜV 03 ATEX 7131x ExII2 G Ct5

## Programming of angular transmitters

Programming of encoders, label FSG, with servo mount sizes 13 and 23

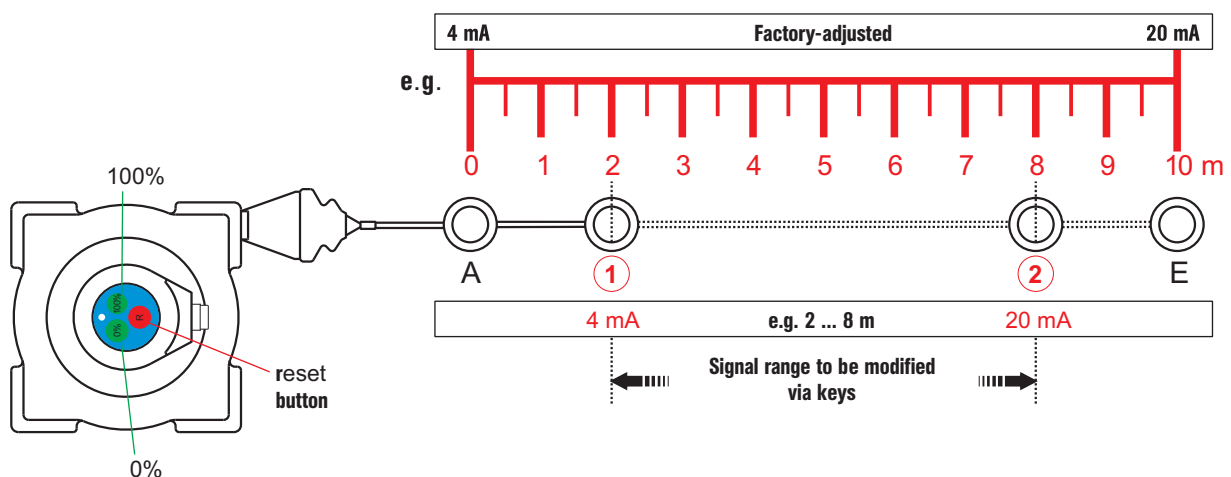

### ... easy signal correction

The encoders are factory-adjusted at nominal length to 4 ... 20 mA. In case of deviating lengths signal correction can be carried out easily via push buttons. A reversal of direction of rotation is likewise easy by using the push buttons.

1. Programming mode "on"  
2 x briefly red ( R; R )
2. Drive transmitter to initial position ①  
0 % to be set  
1 x briefly left ( 0 % )
3. Drive transmitter to final position ②  
100 % to be set  
1 x briefly right ( 100 % )
4. Programming mode "off"  
2 x briefly red ( R; R )

# Attachment of encoders

To determine the unwound measuring length single or multi-turn encoders are applicable.

For use of a single turn transmitter at a draw wire mechanism, which makes more than one drum revolution, the use of a gearing is necessary. For use of multi-turn transmitters appropriate couplings are available for adaptation purposes.

## Gearing:

For this purpose a modular structure is available for backlash compensated application with all encoding systems customary in trade of **servo mount sizes 13** and **23**, ensuring a speed reducing ratio of 1: 4 up to 1: 128.

Transmission gradation					
1: 4	1: 8	1: 16	1: 32	1: 64	1: 128

## Function mode:

The backlash reduced gear-wheels are kept backlash compensated by an driving shaft arrangement. In this case the driving gear wheel as well as a spring unit, being under pretension, are mounted onto the shaft of the encoder.

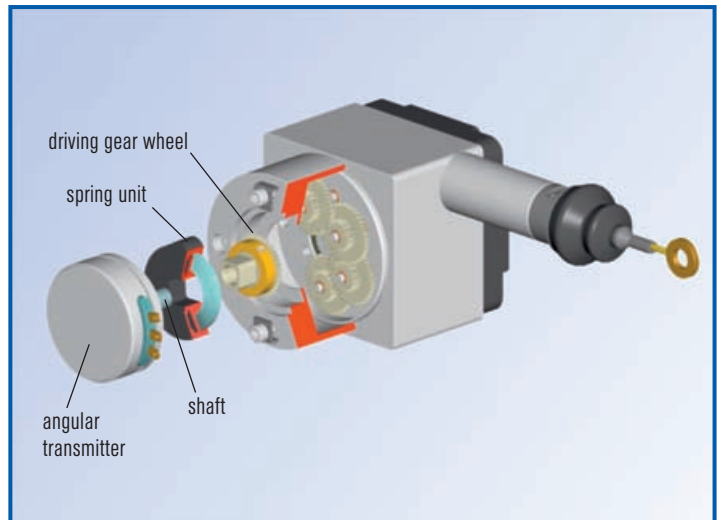

## Coupling:

The existing plastic couplings ensure a completely unproblematical coupling of every transmitter system customary in trade. According to standard all angular transmitters of **servo mount sizes 13** and **23** having a shaft diameter of 6 mm, 6.35 mm and 10 mm may be adapted backlash compensated.

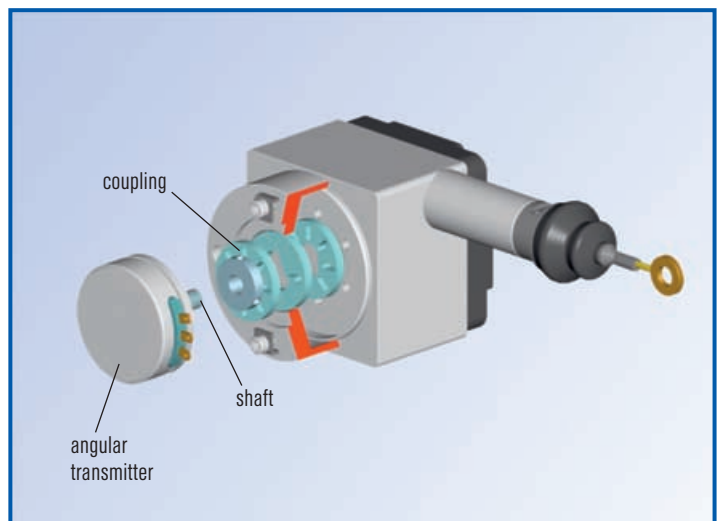

# Rope Length Transmitters of series SL00

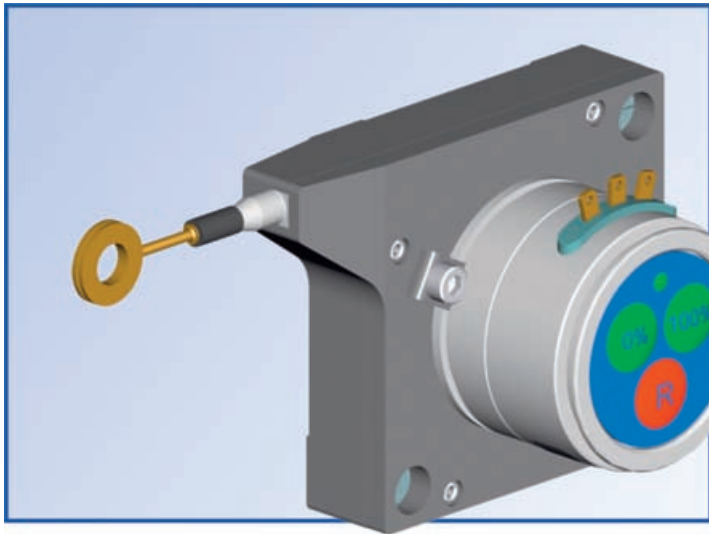

## Characteristics of series SL00:

- Low-cost version
- Flat design
- Light-weight plastic design
- Various mounting possibilities
- Drum bearing carried out by the shaft of the flanged encoder which is available as measuring system of the potentiometric, magnetic or optic manner

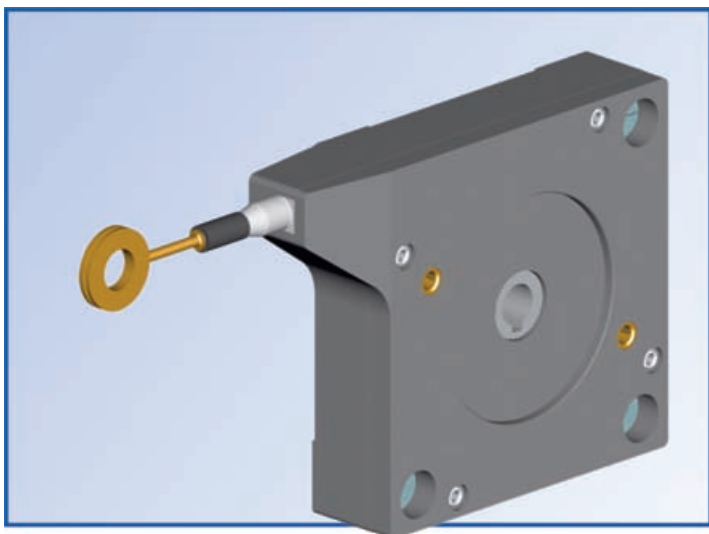

## Attachment of encoders customary in trade

This series may be equipped with our angular transmitters as well as with all encoding systems customary in trade with **servo mount sizes 13 and 23** having a shaft diameter of 6 mm to be adapted via coupling or gearing.

As far as the direct coupling of an encoder is concerned, the shaft is designed to have a groove for the feather key in order to ensure a hollow shaft coupling.

shaft bearing of version SL00

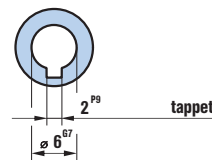

shaft design of angular transmitter

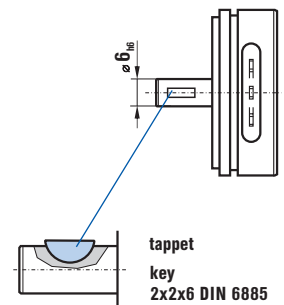

### Mechanical data

	SL00 125 GS 55	SL00 1250 GS 55	SL00 200 GS 80	SL00 3000 GS 80	SL00 300 GS 130	SL00 5000 GS 130
Measuring length up to	0.125 m	1.25 m	0.2 m	3 m	0.3 m	5 m
Circumference of drum	150 mm	150 mm	230 mm	230 mm	385 mm	385 mm
Measuring wire diameter	0.81 mm	0.45 mm	0.81 mm	0.55 mm	0.81 mm	0.55 mm
Accuracy of drum	±0.05 %	±0.05 %	±0.05 %	±0.05 %	±0.05 %	±0.05 %
Speed of adjustment	8 m/s	6 m/s	8 m/s	6 m/s	8 m/s	6 m/s
Force of retractile spring	1.4 N	1 - 1.4 N	6.3 N	5 - 6.3 N	7 N	4.5 - 7 N
Casing material	plastic, Noryl	plastic, Noryl	plastic, Noryl	plastic, Noryl	plastic, Noryl	plastic, Noryl
IP code of casing	IP30	IP30	IP30	IP30	IP30	IP30
Material of measuring wire	1.4401	1.4401	1.4401	1.4401	1.4401	1.4401
Weight (without encoder)	80 g	80 g	250 g	250 g	800 g	800 g
<b>Dimensions (mm)</b>						
A	6.5	6.5	10.5	10.5	13	13
B	15.5	15.5	24.7	24.7	27.2	27.2
C	8.5	8.5	14.5	14.5	17	17
D	44	44	67	67	110	110
E	55	55	80	80	130	130
F	ca. 48	ca. 48	ca. 73	ca. 73	ca. 90	ca. 90
G	23.5	23.5	36	36	61	61
M	M3 x 6	M3 x 6	M4 x 8	M4 x 8	M6 x 12	M6 x 12
K	∅ 3.2 x 11	∅ 3.2 x 11	∅ 4.2 x 16	∅ 4.2 x 16	∅ 6.2 x 20	∅ 6.2 x 20
L	27 - 47*	27 - 47*	90	90	92.5	92.5
h / d1 / d2	2 / 6 / 12	2 / 6 / 12	2 / 6 / 12	2 / 6 / 12	2 / 6 / 12	2 / 6 / 12

\* depends on attached encoder

### Electrical data

Servo mount size (transmitter)	13	13	23	23	23	23
Potentiometric 1, 2 or 5 kΩ						
Magnetic (absolute) 0 - 20 mA or 4 - 20 mA						
Magnetic (absolute) CAN / CAN open						
Magnetic (incremental) up to max. 2000 pulses / 360°						

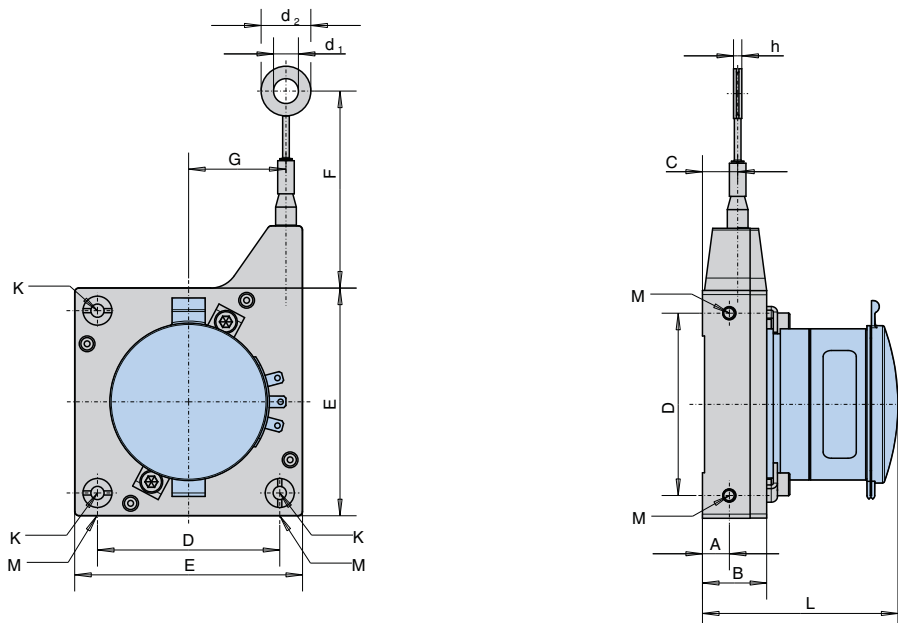

## Rope Length Transmitters of series SLO

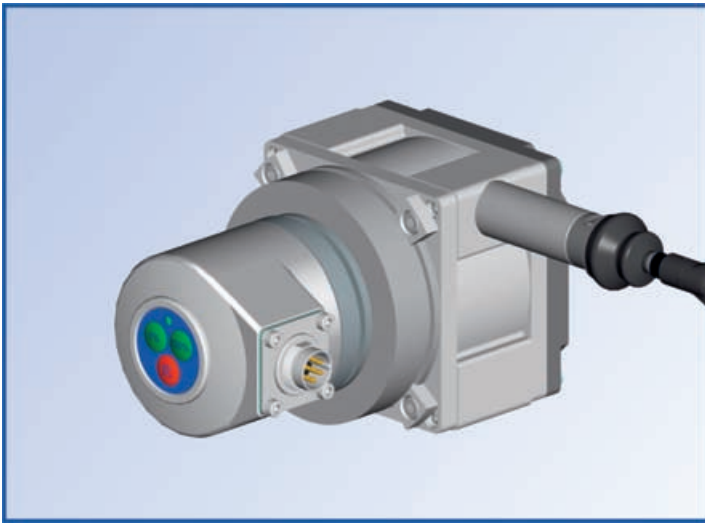

### Characteristics of series SLO:

- Rugged drum casing, material: aluminium
- Reliable wire outlet by bellows with cross role arrangement
- Low-priced option to series SL

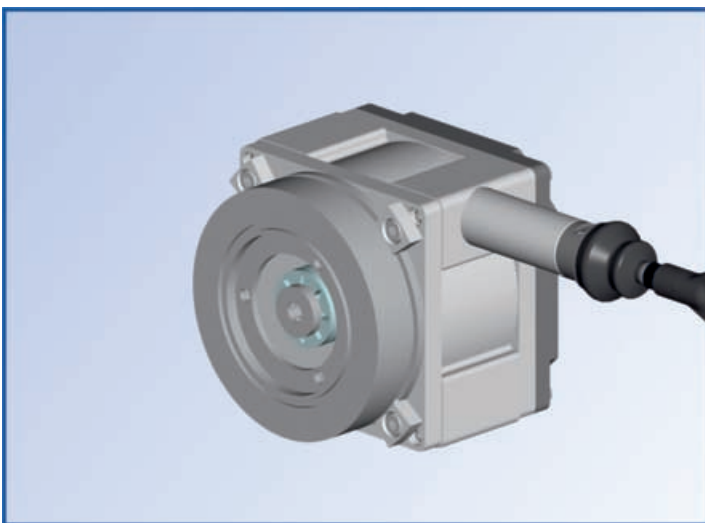

### Attachment of encoders customary in trade

















Series SLO may be equipped with our angular transmitters as well as with all encoding systems customary in trade with **servo mount sizes 13 and 23** having a shaft diameter of 6 mm, 6.35 mm and 10 mm to be adapted via coupling or gearing.

### Mechanical data

	SL 01.5 GS 55	SL 02...03 GS 80		SL 05 GS 130
Measuring length up to	1.5 m	2 m	3 m	5 m
Circumference of drum	125 mm	200 mm	200 mm	333.3 mm
Measuring wire diameter	0.55 mm	0.55 mm	0.55 mm	0.55 mm
Accuracy of drum	±0.05 %	±0.05 %	±0.05 %	±0.05 %
Speed of adjustment	4 m/s	4 m/s	4 m/s	4 m/s
Force of retractile spring	4 - 6 N	5 - 15 N	5 - 15 N	15 - 20 N
Casing material	aluminium	aluminium	aluminium	aluminium
IP code of casing	IP50 *	IP65	IP65	IP65
Material of measuring wire	1.4401	1.4401	1.4401	1.4401
Weight (without encoder)	0.5 kg	1.0 kg	1.1 kg	2.0 kg
<b>Dimensions (mm)</b>				
A	42.5	34.7	56.4	59.5
B	76.4	78.2	99.9	106
C	26.5	34.7	56.4	59.5
D	46	50	50	80
E	55	80	80	130
F	ca. 90	ca. 115	ca. 115	ca. 115
G	18.5	30.5	30.5	54
M	M4 x 8	M6 x 7	M6 x 7	M8 x 8
L	88.4 - 106.4**	145.2	166.9	173
h / d1 / d2	2 / 6 / 12	6 / 20 <sub>H7</sub> / 29	6 / 20 <sub>H7</sub> / 29	6 / 20 <sub>H7</sub> / 29

\* (IP 65 on request) \*\* depends on attached encoder

### Electrical data

Servo mount size (transmitter)	13	23	23	23
Potentiometric 1, 2 or 5 kΩ				
Magnetic (absolute) 0 - 20 mA or 4 - 20 mA				
Magnetic (absolute) CAN / CAN open				
Magnetic (incremental) up to max. 2000 pulses / 360°				

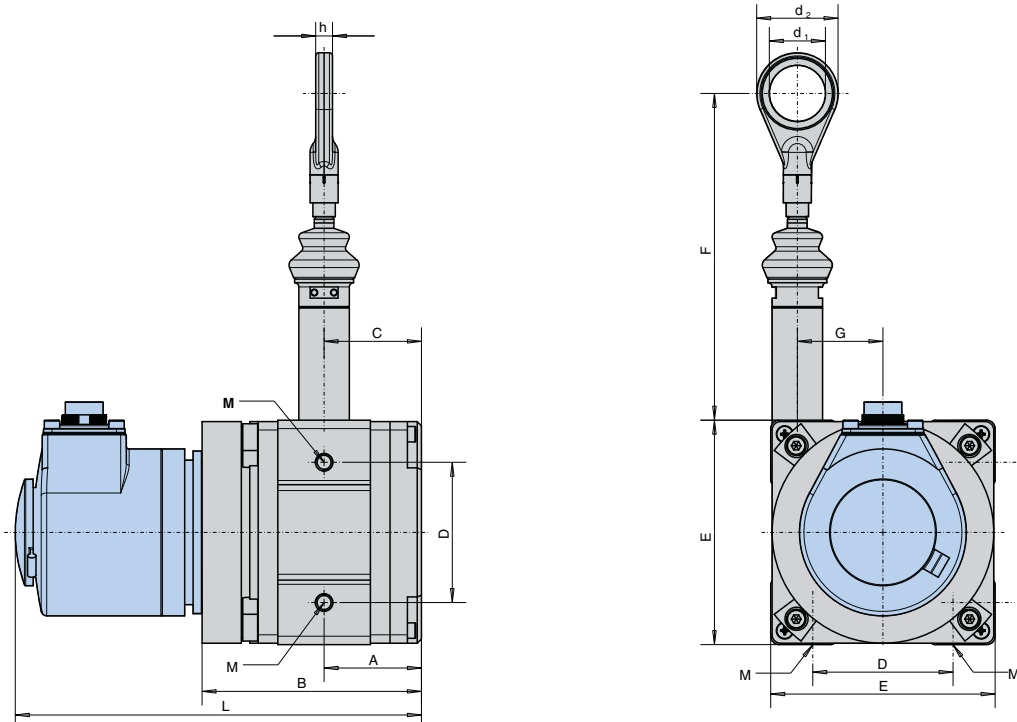

# Rope Length Transmitters of series SL

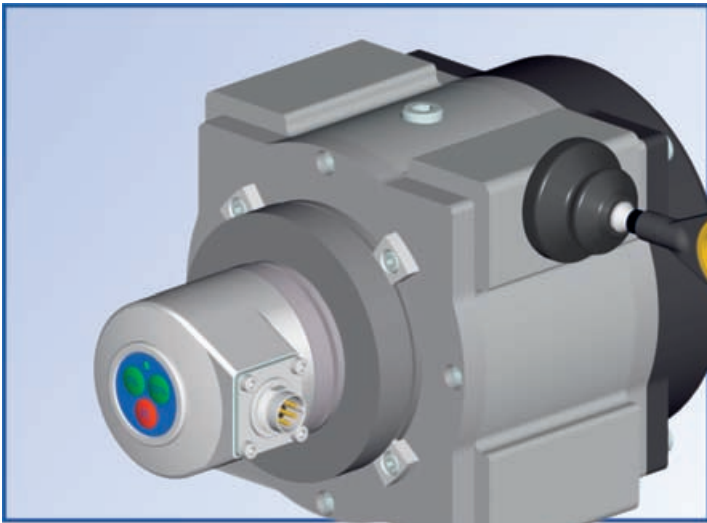

## Characteristics of series SL:

- Patented drum mechanism:  
A highly flexible measuring wire consisting of stainless and acid-resistant high-grade steel is wound on a precision measuring drum driven by a coil spring drive. During unwinding procedure the measuring drum is moved in axial direction via a threaded spindle, thereby ensuring the measuring wire to be unwound constantly side by side with constant distance. The drum revolutions will be transmitted to a suitable transmitter system (depending on application) via a backlash compensated coupling or a backlash compensated measuring gear unit.
- Rugged drum casing, material: aluminium
- Advanced working reliability and measuring accuracy
- For different applications extensive accessories are available: wire guide pulley, compressed air inlet etc.

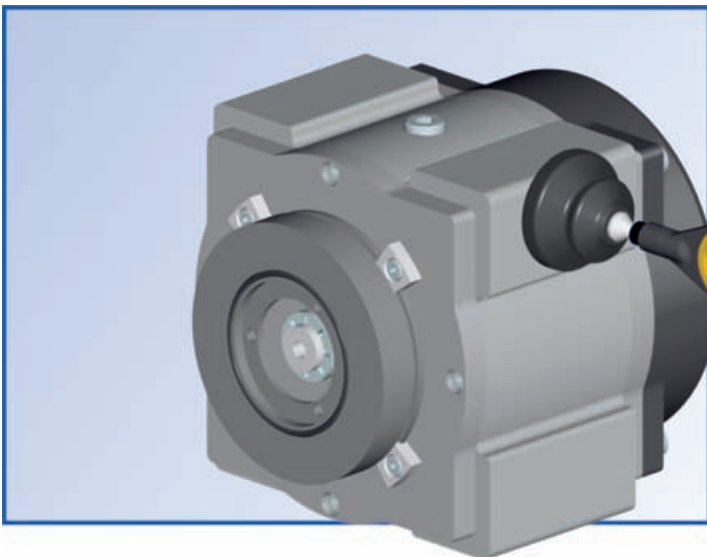

## Attachment of encoding systems customary in trade

Series SL may be equipped with our angular transmitters as well as with all encoding systems customary in trade with **servo mount sizes 13 and 23** having a shaft diameter of 6 mm, 6.35 mm and 10 mm to be adapted via coupling or gearing.

**Mechanical data**

	SL 3002 GS 55	SL 3001...3003 GS 80			SL 3005...3030 GS 130						SL 3015...3030 GS 190					
Measuring length up to	2 m	1 m	2 m	3 m	5 m	10 m	15 m	20 m	25 m	30 m	15 m	20 m	25 m	30 m	35 m	40 m
Circumference of drum	125 mm	200 mm	200 mm	200 mm	334.1 mm	334.1 mm	334.1 mm	334.1 mm	334.1 mm	334.1 mm	491.5 mm	491.5 mm	491.5 mm	491.5 mm	491.5 mm	491.5 mm
Measuring wire diameter	0.55 mm	1.35 mm	1.35 mm	1.35 mm	1.35 mm	1.35 mm	1.35 mm	1.35 mm	1.35 mm	1.35 mm	1.35 mm	1.35 mm	1.35 mm	1.35 mm	1.35 mm	1.35 mm
Accuracy of drum	±0.05 %	±0.05 %	±0.05 %	±0.05 %	±0.05 %	±0.05 %	±0.05 %	±0.05 %	±0.05 %	±0.05 %	±0.05 %	±0.05 %	±0.05 %	±0.05 %	±0.05 %	±0.05 %
Speed of adjustment	4 m/s	4 m/s	4 m/s	4 m/s	4 m/s	4 m/s	4 m/s	4 m/s	4 m/s	4 m/s	4 m/s	4 m/s	4 m/s	4 m/s	4 m/s	4 m/s
Force of retractile spring	3.5 - 6 N	5 - 15 N	5 - 15 N	5 - 15 N	10 - 21 N	10 - 21 N	10 - 21 N	10 - 21 N	10 - 21 N	10 - 21 N	18 - 37 N	18 - 37 N	18 - 37 N	18 - 37 N	18 - 37 N	18 - 37 N
Casing material	aluminium	aluminium	aluminium	aluminium	aluminium	aluminium	aluminium	aluminium	aluminium	aluminium	aluminium	aluminium	aluminium	aluminium	aluminium	aluminium
IP code of casing	IP50*	IP65	IP65	IP65	IP65	IP65	IP65	IP65	IP65	IP65	IP65	IP65	IP65	IP65	IP65	IP65
Material of measuring wire	1.4401	1.4401	1.4401	1.4401	1.4401	1.4401	1.4401	1.4401	1.4401	1.4401	1.4401	1.4401	1.4401	1.4401	1.4401	1.4401
Weight (without encoder)	0.6 kg	0.9 kg	1.1 kg	1.5 kg	2.5 kg	3.5 kg	5.0 kg	6.0 kg	7.5 kg	8.5 kg	7.5 kg	9.3 kg	11.5 kg	14.2 kg	16 kg	20 kg
<b>Dimensions (mm)</b>																
A	42.5	34	41.5	70.9	77.4	99.9	146.4	168.9	215.4	237.9	99.7	114.9	157.2	172.5	187.7	202.9
B	88	77	92	128.9	141.7	187	256	301	370	415	186	217	274	305	335	366
C	26.5	34	41.5	70.9	77.4	99.9	146.4	168.9	215.4	237.9	99.7	114.9	157.2	172.5	187.7	202.9
D	46	50	50	50	80	80	80	80	80	80	140	140	140	140	140	140
E	55	80	80	80	130	130	130	130	130	130	190	190	190	190	190	190
F	ca. 60	ca. 100	ca. 100	ca. 100	ca. 80	ca. 80	ca. 80	ca. 80	ca. 80	ca. 80	ca. 80	ca. 80	ca. 80	ca. 80	ca. 80	ca. 80
G	19.5	31.5	31.5	31.5	54	54	54	54	54	54	79	79	79	79	79	79
M	M4 x 8	M6 x 7	M6 x 7	M6 x 7	M8 x 8	M8 x 8	M8 x 8	M8 x 8	M8 x 8	M8 x 8	M10 x 10	M10 x 10	M10 x 10	M10 x 10	M10 x 10	M10 x 10
L	100-118**	144	159	195.9	207.7	253	322	367	436	481	252	283	340	371	401	432
h / d1 / d2	2 / 6 / 12	6 / 20 <sub>h7</sub> / 29	6 / 20 <sub>h7</sub> / 29	6 / 20 <sub>h7</sub> / 29	6 / 20 <sub>h7</sub> / 29	6 / 20 <sub>h7</sub> / 29	6 / 20 <sub>h7</sub> / 29	6 / 20 <sub>h7</sub> / 29	6 / 20 <sub>h7</sub> / 29	6 / 20 <sub>h7</sub> / 29	6 / 20 <sub>h7</sub> / 29	6 / 20 <sub>h7</sub> / 29	6 / 20 <sub>h7</sub> / 29	6 / 20 <sub>h7</sub> / 29	6 / 20 <sub>h7</sub> / 29	6 / 20 <sub>h7</sub> / 29

\* (IP 65 on request) \*\* depends on attached encoder

**Electrical data**

Servo mount size (transmitter)	13	23	23	23	23	23	23	23	23	23	23	23	23	23	23	23
Potentiometric 1, 2 oder 5 kΩ	<input type="checkbox"/>	<input type="checkbox"/>	<input type="checkbox"/>	<input type="checkbox"/>	<input type="checkbox"/>	<input type="checkbox"/>	<input type="checkbox"/>	<input type="checkbox"/>	<input type="checkbox"/>	<input type="checkbox"/>	<input type="checkbox"/>	<input type="checkbox"/>	<input type="checkbox"/>	<input type="checkbox"/>	<input type="checkbox"/>	<input type="checkbox"/>
Magnetic (absolute) 0 - 20 mA or 4 - 20 mA	<input type="checkbox"/>	<input type="checkbox"/>	<input type="checkbox"/>	<input type="checkbox"/>	<input type="checkbox"/>	<input type="checkbox"/>	<input type="checkbox"/>	<input type="checkbox"/>	<input type="checkbox"/>	<input type="checkbox"/>	<input type="checkbox"/>	<input type="checkbox"/>	<input type="checkbox"/>	<input type="checkbox"/>	<input type="checkbox"/>	<input type="checkbox"/>
Magnetic (absolute) CAN / CAN open	<input type="checkbox"/>	<input type="checkbox"/>	<input type="checkbox"/>	<input type="checkbox"/>	<input type="checkbox"/>	<input type="checkbox"/>	<input type="checkbox"/>	<input type="checkbox"/>	<input type="checkbox"/>	<input type="checkbox"/>	<input type="checkbox"/>	<input type="checkbox"/>	<input type="checkbox"/>	<input type="checkbox"/>	<input type="checkbox"/>	<input type="checkbox"/>
Magnetic (incremental) up to max. 2.000 pulses / 360°	<input type="checkbox"/>	<input type="checkbox"/>	<input type="checkbox"/>	<input type="checkbox"/>	<input type="checkbox"/>	<input type="checkbox"/>	<input type="checkbox"/>	<input type="checkbox"/>	<input type="checkbox"/>	<input type="checkbox"/>	<input type="checkbox"/>	<input type="checkbox"/>	<input type="checkbox"/>	<input type="checkbox"/>	<input type="checkbox"/>	<input type="checkbox"/>

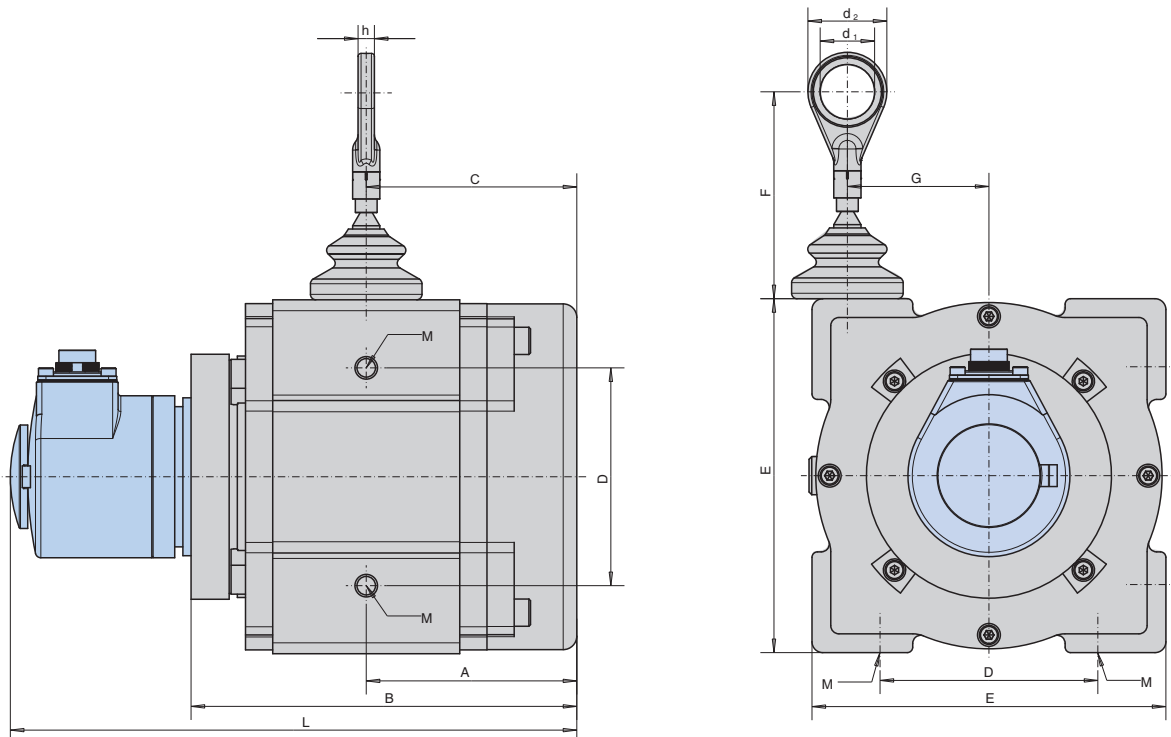

**Berlin****Fernsteuergeräte****Kurt Oelsch GmbH**

Jahnstraße 68 + 70

D - 12347 Berlin

Phone + 49 (30) 62 91 - 1

Fax + 49 (30) 62 91 - 277

[www.fernsteuergeraete.de](http://www.fernsteuergeraete.de)[info@fernsteuergeraete.de](mailto:info@fernsteuergeraete.de)**Kablow****FSG Fernsteuergeräte****Meß- und Regeltechnik GmbH**

OT Kablow

Mühlenweg 2 - 3

D - 15712 Königs Wusterhausen

Phone + 49 (33 75) 269 - 0

Fax + 49 (33 75) 269 - 277

**Heppenheim****Fernsteuergeräte****Kurt Oelsch GmbH & Co.KG**

Weiherhausstraße 10

D - 64646 Heppenheim

Phone + 49 (62 52) 99 50 - 0

Fax + 49 (62 52) 72 05 - 3