

Measurement and Sensor Systems with conception



Angular Position Transducers



Angular Position Transducers

For measuring angular positions and converting them into electrical signals for teletransmission purposes, either **potentiometric** (see data sheet „precision rotary potentiometer“), **inductive, magnetic, incrementally** or absolutely **coded** angular position transducers can be used according to the particular application.

Inductive angular position transducers of the non-contacting type are preferably used on measuring points, which are exposed to extreme vibration or shock or to aggressive atmospheres.

This applies mainly to measurement problems one is confronted with in energy industry and chemical plants, for instance while measuring the actual value of the position of variable speed drives, or of machines in paper-processing and textile industry, while measuring the position of dancer rollers and very frequently in pendulum systems for measuring tilt angles on cranes and excavators.

Optoelectronic angular position transducers possess code disks, whose tracks are digitally scanned.

They are high-resolution measuring systems with low temperature coefficient, available in a single- or multi-turn version, outputting analogue or digitally coded signals.

Single-turn transducers are used e. g. in the railway vehicle domain in connection with master controllers or on cranes as slewing ring transmitters.

Multi-turn transducers are preferably used together with rope length measuring systems on hauling plants, bearer cable winches of crane systems or in the field of machine tool engineering for sensing the tool position.

Magnetic angular position transducers are extremely robust measuring systems completely hermetically encapsulated of two-chamber design with a protection degree of IP 68.

In shaft exit design e. g. they are used to record the angular position of a permanent magnet mounted on the measuring object.

Transducers of this type are predominately used in commercial vehicles for sensing the position of steering type axles or the angle of the articulated arm of excavators.

Transducers with shaft exit also contain a hermetically encapsulated electronic unit. They are universally used in mechanical engineering exposed to extreme atmospheres in order to record angular positions.

Signals of the single- or multi-turn version are output either analogue as current or voltage signals or digital as CAN open configuration.

Application range

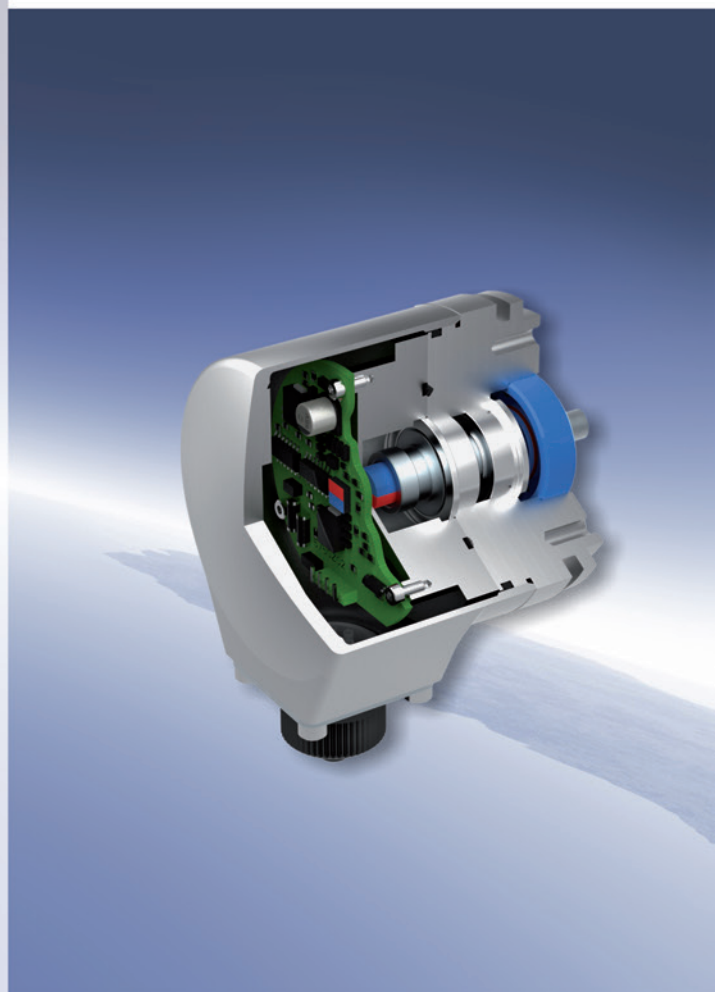

Measuring systems

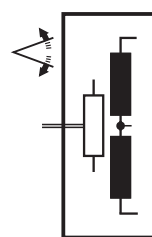

Inductive

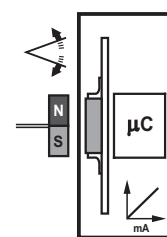

Magnetic

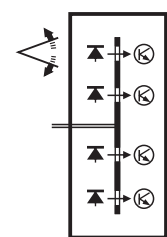

Optoelectronic

System versions

WD



Differential inductor

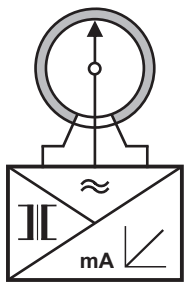

Inductive transducer systems (WD)

are available as models of synchro size 20 (series 620) and synchro size 23 (series 1023).

They contain a differential inductor designed in form of a ring winding with a non-contact tapping.

The electrical output signals representing zero and final value of the mechanical drive shaft angle are available within a broad range of limits via trimming potentiometers of the incorporated or separate electronics.

For use in explosive installations, transducer systems as well as electronic components are available with a degree of protection EEx and Exd with ATEX approval.



MH



Permanent magnet

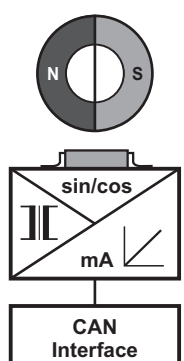

Magnetic transducer systems (MH)

are available as models of synchro sizes 9, 13, 20 and 23.

They are fully enclosed in an aluminium casing of two chamber design and contain a permanent magnet with a high-precision angular encoder.

Signals are output either analogue, e. g. with 4 - 20 mA, or digitally coded (CAN open standard).

Output signal of transducers with analogue output can be programmed via rear keys of transducer to the respective measuring range.

For safety-relevant applications these systems are also available in redundant version according to IEC 61508 (SIL).

Xi u. XA



Coded disk

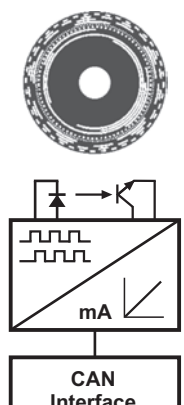

Optoelectronic transducer systems (XI and XA)

are available as models of synchro size 23 in incremental and absolute coded design.





Incremental systems convert the angle to be measured into a proportional number of pulses, appearing in two tracks A and B with an offset of 90° for identification of direction.

Absolutely coded systems are available as single- or multi-turn encoders.





They contain a gray-coded rotating disk whose 12 concentric tracks are optically scanned by infrared diodes and phototransistors.

Signals are output parallel via NPN or PNP transistors or analogue via a digital-to-analogue converter with current output 4 - 20 mA. All transducers can also be supplied with field bus interface CAN open standard and in user-specific data format respectively.

Specifications

System versions	Magnetic systems									
Models										
Series	MH 609		MH 613		MH 620	MH 1023		MH 1023 ext		
Single-turn / multi-turn	single-turn	multi-turn	single-turn	multi-turn	single-turn	single-turn	multi-turn	single-turn		
Synchro size	9		13		20	23		special size		
Casing - Ø	22,2 mm		36,5 mm		50,8 mm	60 mm		60 mm		
Shaft - Ø	6 mm		6 mm		6 mm	6 / 10 mm		external magnet		
Angle of rotation max.	360°	1080°	360°	5760°	360°	360°	23040°	360°		
Revolution max.	1	3	1	16	1	1	64	1		
Voltage output	0,5 - 4,5 V		0 - 10 V		0 - 10 V	0 - 10 V		0 - 10 V		
Current output	-		4 - 20 mA		4 - 20 mA	4 - 20 mA		4 - 20 mA		
Pulse output	-		-		-	-		-		
Bus output	-		-		CAN / CANopen	CAN / CANopen		CAN / CANopen		
Redundant electronics	-		-		4 - 20 mA / CAN	4 - 20 mA / CAN		4 - 20 mA / CAN		
Signal adjustment via	fixed alignment		keys		cable	keys or CAN-Bus		fixed alignment		
Linearity	± 0,5 %	± 0,1 %	± 0,3 %		± 0,2 %	± 0,2 %		± 0,2 %		
Resolution	12 bit		12 bit	16 bit	14 bit	14 bit		14 bit		
Supply	5 V DC		18 - 33 V DC		1 x or 2 x 18 - 33 V DC	18 - 33 V DC		18 - 33 V DC		
Current consumption	< 80 mA		< 80 mA		< 80 mA	< 80 mA		< 80 mA		
IP code of casing up to	IP 67		IP 65		IP 67	IP 68		IP 68		
Connection	standard wire		solder-type terminals / cable		cable	plug / cable		plug / cable		
Weight	100 g		100 g		200 g	400 g		400 g		
Approval	-		-		-	-		TÜV		
Article number	1130Z01	1140Z01	2740Z01	2750Z01	2845Z01	5750Z02	5755Z02	5850Z01		

General data	
Casing material	alu, anodized, partly varnished, special version: saline-resistant coating HART-COAT
Shaft material	stainless steel
Shaft bearing	ball bearing
Temperature range	-30°C up to +70°C, other ranges on request
Test voltage	500 V, 50 Hz, 1 min
Immunity standard	EN 50 082-2
Emission standard	EN 50 081-1
Shock	50 g, 6 ms
Vibration	4 g Sinus 5 - 100 Hz
Current output	$R_i \leq 6000 \Omega$ 3 wire system, 2 and 4 wire system on request
Voltage output	$R_i \geq 10 \text{ k}\Omega$ 4 wire system
Supply voltage	18 - 33 V DC, other supply on request

System versions	Magnetic systems		2-fold systems	Inductive systems			
Models							
Series	MH 670	MH 4096	Xi / MH 1023	XA 1023		WD 620*	WDG 620*
Single-turn / multi-turn	single-turn	multi-turn	single-turn	single-turn	multi-turn	single-turn	
Synchro size	special construction	special construction	23	23		20	
Casing - Ø	70 mm	61,5 mm	60 mm	60 mm		50,8 mm	
Shaft - Ø	6 mm	10 mm	6 / 10 mm	6 / 10 mm		6 mm	
Angle of rotation max.	360°	4096 revolutions	360°	360°	23040°	90°	360°
Revolution max.	1	4096	1	1	64	1	
Voltage output	-	-	-	-		0 - 10 V**	
Current output	4 - 20 mA / two-wire	-	4 - 20 mA	4 - 20 mA		4 - 20 mA	
Pulse output	-	-	max. 3.600 pulses	-		-	
Bus output	-	profi-bus/CAN/CANopen	-	CANopen		-	
Redundant electronics	-	-	4 - 20 mA / 3.600 pulses	-		-	
Signal adjustment via	membrane key	-	fixed alignment	fixed alignment		trimmer	
Linearity	± 0,35°	± 0,3°	± 0,2 %	± 0,2 %		± 0,5 %	
Resolution	12 bit / 360°	12 + 12 bit	14 bit / 720 pulses	12 bit	16 bit	∞	
Supply	18 - 33 V DC	10 - 30 V DC	2 x 18 - 33 V DC	18 - 33 V DC		18 - 33 V DC	
Current consumption	4 - 20 mA	-	< 80 mA	< 80 mA		< 60 mA	
IP code of casing up to	IP 54 (IP 65)	IP 68	IP 68	IP 67		IP 30	
Connection	plug	cable	plug / cable	plug / cable		solder-type terminals	
Weight	450 g	600 g	500 g	400 g		60 g	120 g
Approval	-	-	-	-		Atex	
Article number	5550S01	5756Z01	5770Z02	5740Z02	5730Z02	9252Z10	9253Z10

* series WD also available in intrinsically safe version, see page 10



** only via external electronic, see page 10

Wiring

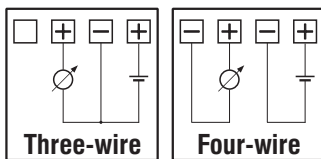

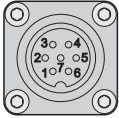
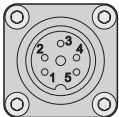
Terminal connecting plan		color of standard wire or cable	solder-type terminals
cable / standard wire supply	Us +	green	5
	0 V	brown	4
V- or mA output	+	yellow	25
	-	white	24
plug 7-poles	supply Us +	6	
	0 V	1	
	output +	2	
	output -	4	
plug 5-poles	supply Us +	2	
	0 V	3	
	CAN-output Low	5	
	CAN-output High	4	



On request also available in version according to IEC 61508, SIL (Safety Integrated Level) or ISO 13849, PL (Performance Level) possible



GL certificate available on request

Models

MH 609

Standard wires

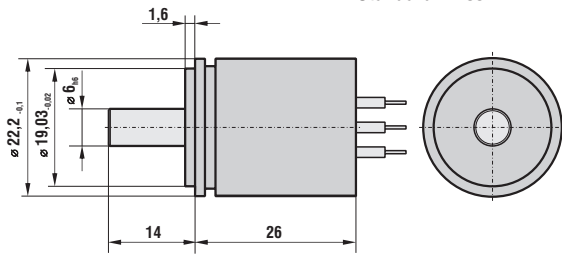

MH 613

Solder-type terminals

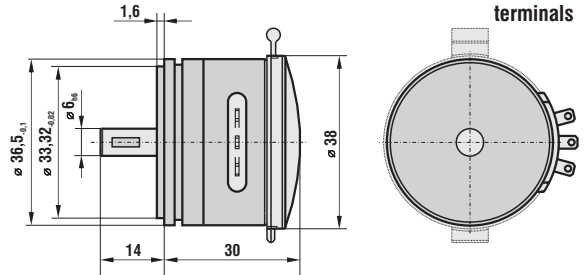

MH 620

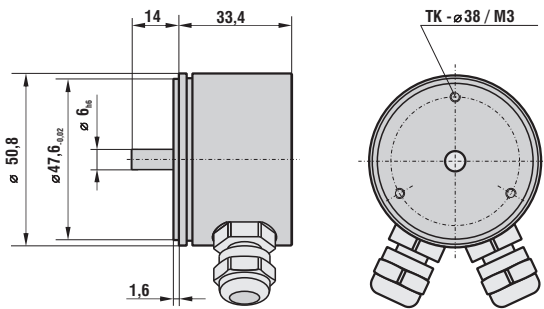

PG screwing with cable outlet



MH 1023

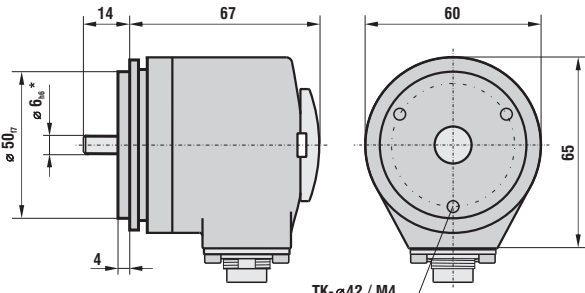

* also ø10_{h6}



MH 1023 ext

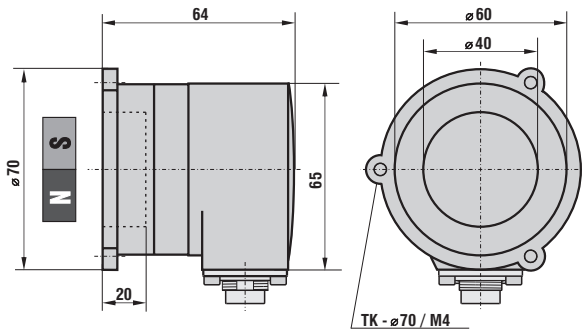

MH 670

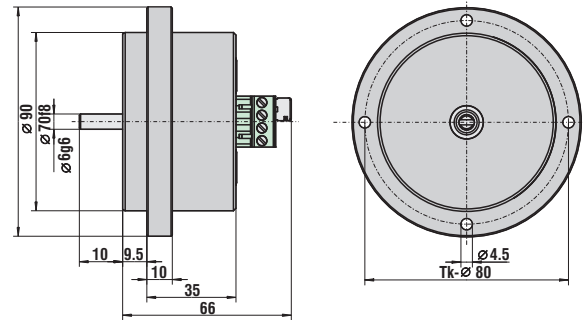

MH 4096

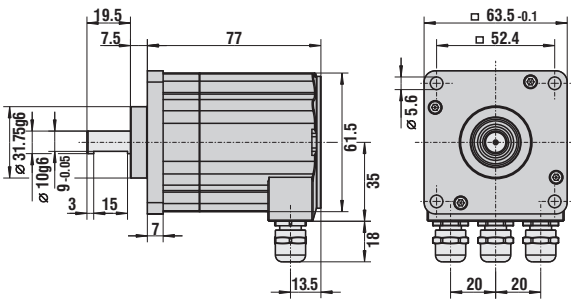

Xi / MR 1023

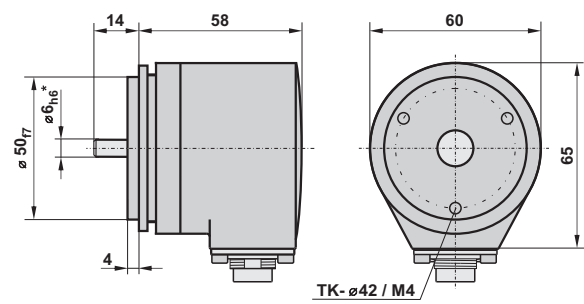

* also $\varnothing 10$ h6



Models

XA 1023

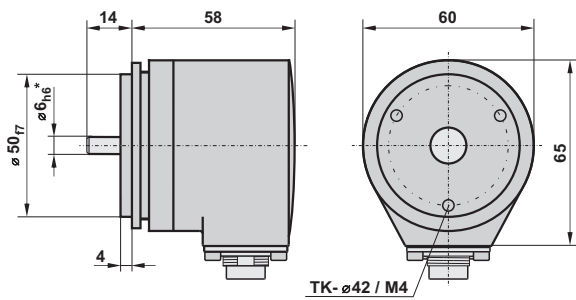

* also $\varnothing 10_{H6}$



WD 620

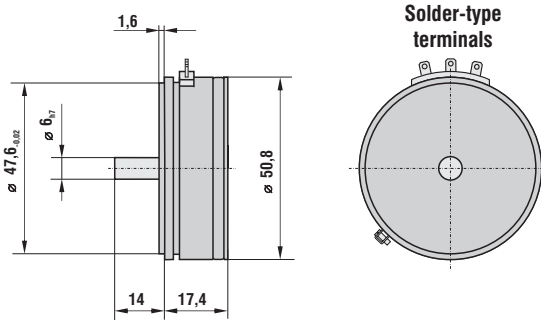

WDG 620

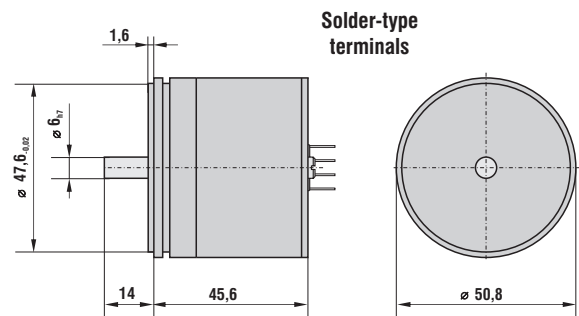

Examples for special versions

Pivot Angle Transducer

- suitable for angle measurement at construction machinery
- flat and robust design in IP code IP 68
- sensor deflection via flange or hinged arm; without primary shaft
- measuring system magnetic, wearless
- signal output 4 - 20 mA or CANopen-interface
- redundant signal measurement and signal output
- conform with SIL2



Feedback Sensor

with optical position indicator

- suitable for position measurements in off-shore range
- small and robust design in IP code IP 65
- position notation via pointer at backside
- measuring system magnetic, wearless
- signal output 2 x 4 - 20 mA or 2 x CANopen-interface
- galvanic isolation between channels as well as between supply and supply voltage



Sensor for measurement of propeller position

- feedback sensor for pitch propeller
- robust design in IP code IP 68
- position notation via pointer at backside
- measuring system magnetic, wearless
- signal output 4 - 20 mA or CANopen-interface
- redundant signal measurement and signal output
- galvanic isolation between channels as well as between supply and output



Cam Shaft Gear

- high-precision angle measurement at construction machinery and elevating platform
- robust design in IP code IP 68
- multiturn transducer with included free of backlash gear
- measuring system magnetic, wearless
- signal output 4 - 20 mA or CANopen-interface / CANopen Safety
- redundant signal measurement and signal output
- conform with SIL2

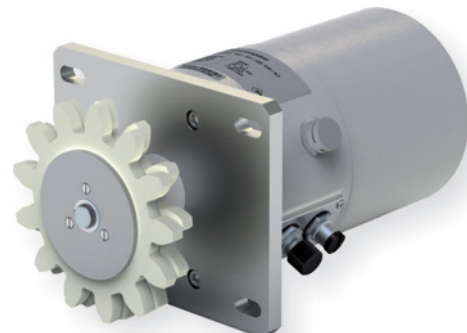

Specifications of separate components

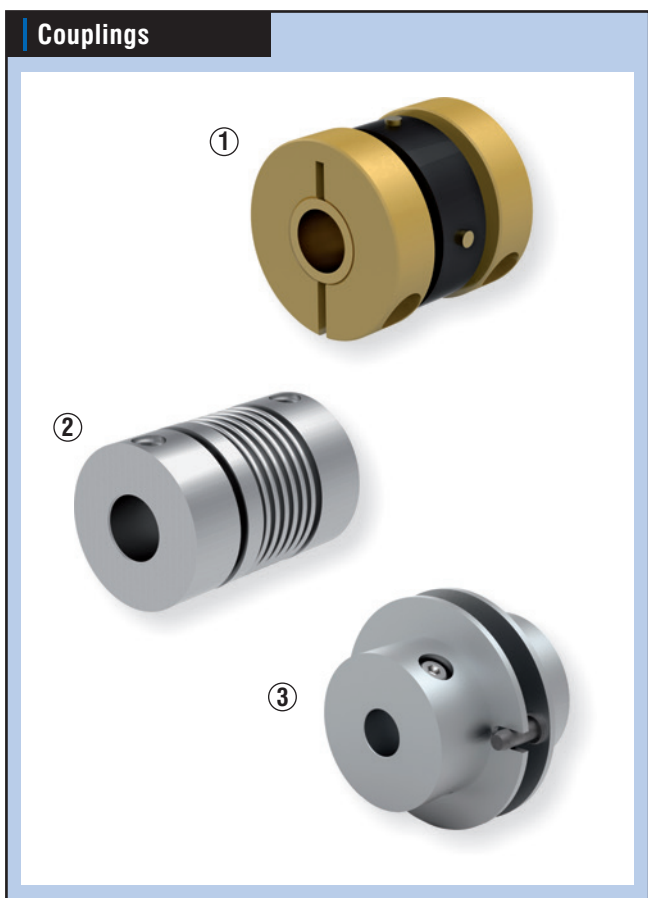

- 1. Unilat coupling for shaft diameter:**
 Ø 4/6 mm
 Ø 6/6 mm, Ø 6/8 mm, Ø 6/10mm, Ø 6/12 mm
 Ø 8/8 mm, Ø 8/10 mm, Ø 8/12 mm
 Ø 10/10 mm, Ø 10/12 mm

Material: Aluminium or brass/plastic

- 2. Balg coupling for shaft diameter:**
 Ø 6/6 mm, Ø 6/10 mm
 Ø 10/10 mm, Ø 10/12 mm
 Ø 12/12 mm

Material: Brass alloy

- 3. Drive coupling for shaft diameter:**
 Ø 6/6 mm, Ø 6/8 mm, Ø 6/10 mm, Ø 6/12mm
 Ø 8/8 mm, Ø 8/10 mm, Ø 8/12 mm
 Ø 10/10 mm, Ø 10/12 mm
 Ø 12/12 mm

Material: Aluminium

Other versions on request.

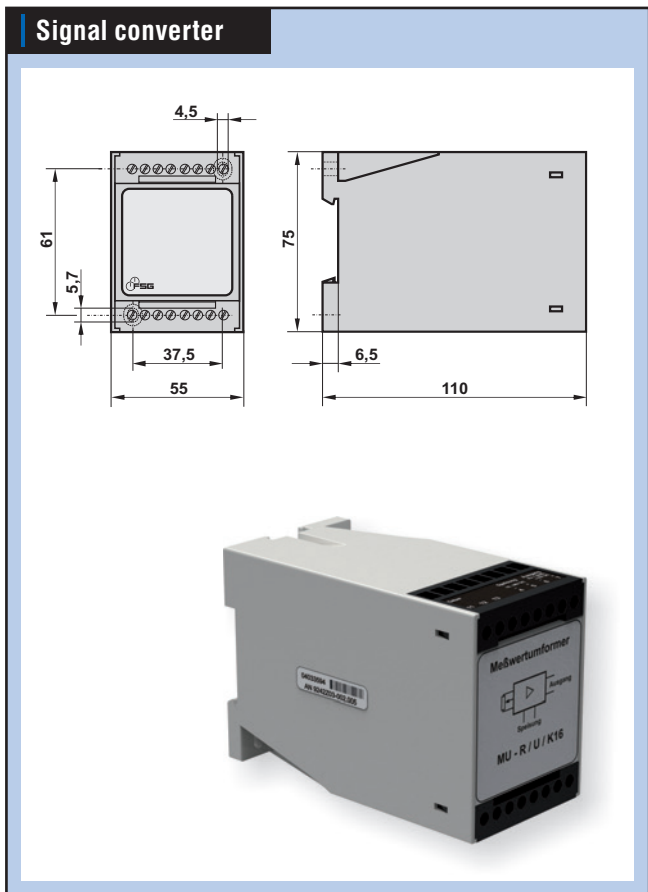

Signal converter

Typ WEVI ... / K16

- Input: signal from transducer series WD
 Output: 0 or 4 - 20 mA, $R_L \leq 600\Omega$
 Supply: 18 - 33 V DC or 230 V AC
 Weight: 300 g
 Article number: 9242Z03

Signal converter

Typ WEVI ... EEX / K16



- Input: signal from transducer series WD
 Output: 0 or 4 - 20 mA, $R_L \leq 600\Omega$ intrinsically safe
 Supply: 18 - 24 V DC intrinsically safe from NBW
 Type of protection: CE0102 EXII(2)G[EEExib]IIC; PTB-Nr. 04 ATEX 2061X
 Weight: 300 g
 Article number: 9249Z51

Power supply with signal isolation

Typ NBW ... EEX / K16



- Input: 4 - 20 mA intrinsically safe
 Output: 4 - 20 mA electrically isolated from input $R_L \leq 600\Omega$
 Supply: 230 V AC
 Type of protection: CE0102 EXII(2)G[EEExib]IIC; PTB-Nr. 04 ATEX 2050
 Weight: 300 g
 Article number: 8249Z02

Specifications of protective casing

GS 100

Technical drawings and photograph of the GS 100 protective casing. Dimensions include: 2xPg11 ports, 22.5° angles, 100mm total width, 24mm mounting flange diameter, 9mm mounting hole, 12mm shaft diameter, 35mm total length, 10mm mounting hole, and 100mm diameter. A photograph shows the physical unit.

Mechanical data	
Casing	aluminium, grey varnished coating
Degree of protection	IP 65 (IP 68)
Shaft material	stainless steel
Bearing	two ball bearings
Bearing friction	1,5 Ncm
Gearing	1:1 up to 256:1 * 1:10 **
Weight	ca. 1,5 kg
Article number	1831S10

Accepts transmitters size 13 and 20, servo mount.

* backlash compensated or reduced backlash
** backlash compensated

GS 150

Technical drawings and photograph of the GS 150 protective casing. Dimensions include: Pg16 port, 40° angle, 25° angle, M8x12 port, 101mm total width, 100mm diameter, 45mm total length, 10mm mounting hole, 12mm shaft diameter, and 150mm diameter. A photograph shows the physical unit.

Mechanical data	
Casing	aluminium, grey varnished coating
Degree of protection	IP 65 (IP 68)
Shaft material	stainless steel
Bearing	two ball bearings
Bearing friction	4 Ncm
Gearing	1:1 bis 1296:9 * 1:1 bis 1:10 **
Weight	ca. 3 ... 8 kg
Article number	1802Z02

Accepts all sizes of transmitters up to an outside diameter of 70 mm.

Incorporating switches is possible.
* backlash compensated or reduced backlash
** backlash compensated

GS 120 EEX

Technical drawings and photograph of the GS 120 EEX protective casing. Dimensions include: 251.3mm total width, 170mm mounting flange diameter, 57.3mm mounting hole diameter, 24mm mounting hole diameter, 3mm mounting hole diameter, 15.2mm mounting hole diameter, 22.5mm mounting hole diameter, 30mm mounting hole diameter, 75mm mounting hole diameter, 120mm diameter, 104mm diameter, 120mm total length, 30mm mounting hole, and 12mm shaft diameter. A photograph shows the physical unit.

Mechanical data	
Casing	aluminium, grey varnished coating
Degree of protection	IP 65
Protection class	EExdIICT6
PTB-No.	PTB 03 ATEX 1062 / 1063X
Shaft material	stainless steel
Bearing	two ball bearings
Bearing friction	1,5 Ncm
Gearing	on demand
Weight	5 kg approximately
Article number	1785Z02



Headquarter in Berlin

Berlin

Fernsteuergeräte

Kurt Oelsch GmbH

Jahnstraße 68 + 70

D-12347 Berlin

Phone +49 (0 30) 62 91 - 1

Fax +49 (0 30) 62 91 - 277



Factory in Kablow

Kablow

FSG Fernsteuergeräte

Meß- und Regeltechnik GmbH

OT Kablow

Mühlenweg 2 -3

D-15712 Königs Wusterhausen

Phone +49 (0 33 75) 269 - 0

Fax +49 (0 33 75) 269 - 277



Factory in Heppenheim

Heppenheim

Fernsteuergeräte

Kurt Oelsch GmbH & Co.KG

Weierhausstraße 10

D-64646 Heppenheim

Phone +49 (0 62 52) 99 50 - 0

Fax +49 (0 62 52) 72 05 - 3



info@fernsteuergeraete.de
www.fernsteuergeraete.de