

Measurement and Sensor Systems



Wind Sensor



Wind Sensor

Anemometer

are used for detecting and, in connection with the appropriate indicator, monitoring a maximum wind velocity. They are used mainly in safety and monitoring systems of cranes and excavators, on ski-lifts and cablecars, wind energy plants as well as in meteorological stations.

Two models are available. One with **pendulum orientation**, especially suited for the attachment on jibs of mobile cranes, and a common one, **pedestal mounted or mounted on a vertical post**.

Because of their particular capsuled assembling both versions, i. e. with **magnetic measuring system** as well as with **generator**, have proved to be very reliable – even under extreme environmental conditions.

Cross arms – with rigid or springy bars – and crown are designed for a reliable outskirts area use. For applications in the temperature range down to minus 50°C there is optionally available a mounting arrangement for an electronic controlled heating device.

For special applications high-quality surfaces and versions for anti-gas areas are available.

The wind velocity indicators are optionally available with different **analogue or digital outputs**.

The Indicator

contains an electronic LED circular bar graph display with a maximum limiting position contact, adjustable from outside. The measuring value is represented in form of a green bar graph display. By a read-out potentiometer on the front side the limit value mark can be preselected within the chain of diodes. If the green shining actual value display passes over the red shining mark of the preselected limiting value, the colour of the actual value display changes to red. At the same time, the limit value relay switches over and signals the passing over the maximum value by switching over a floating contact.

The Switchgear

is an electronic comparator, constructed as a plastic casing, surface-type, suitable for screwing or rail mount according to DIN 46277. Up to a maximum of four limit monitors can be integrated in one casing unit, their switching points can be adjusted separately by means of trimming potentiometers between 0 and 100 % of the input quantity. The output signals are available via floating relay contacts, which are either normally-closed or normally-open contacts.

Application range

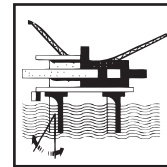
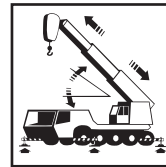

Measuring principle

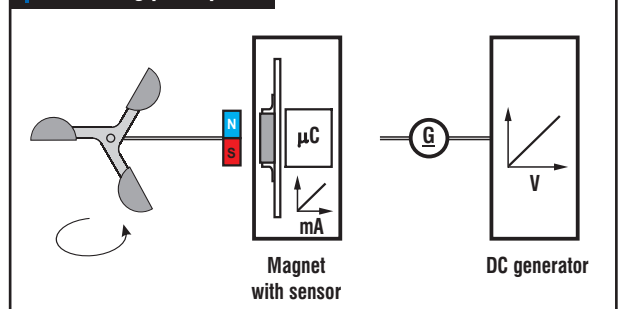

Measuring systems

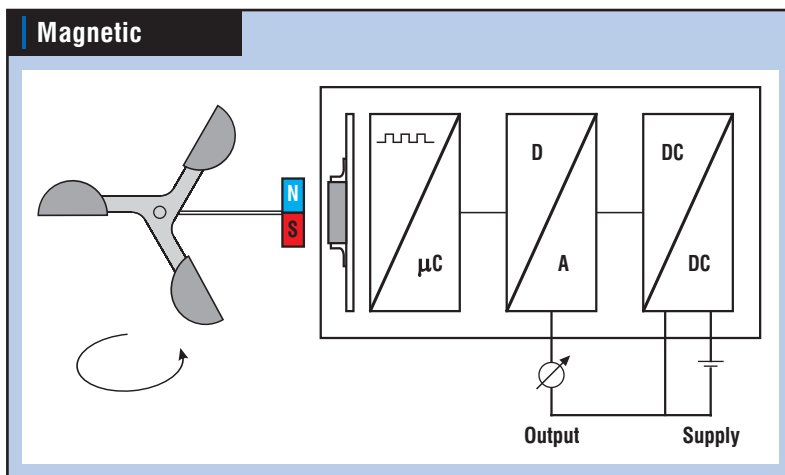

The magnetic measuring system

allows an absolute wear-free and non-contact signal recording, even reliable under extreme environmental conditions. A corrosion-resistant cross arms-driven permanent magnet creates a signal change within the magnet sensor located inside a generally closed aluminium casing.

A downstream processor converts the magnet pulses into an analogue measuring signal of e. g. 4 - 20 or digitally coded (pulse output or CAN signal).

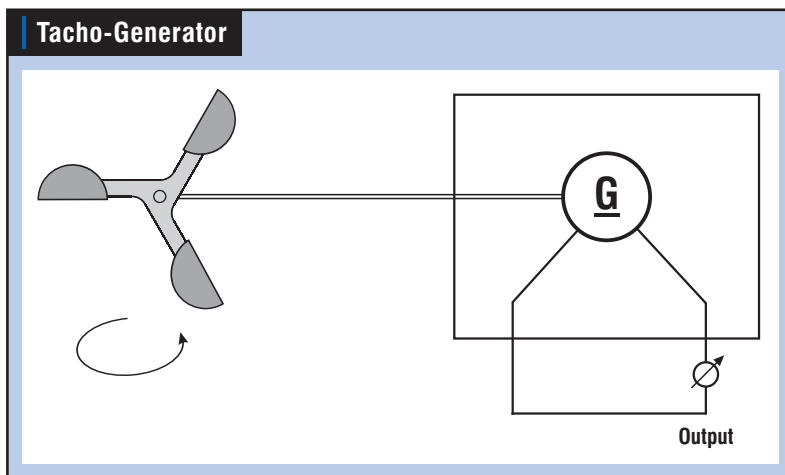

Tacho-Generator

A tacho-generator incorporated into an aluminium casing is driven by the wind speed. Output signal, being proportional to the wind speed is taken in form of a voltage in two-wire circuit.

Specifications

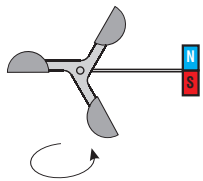
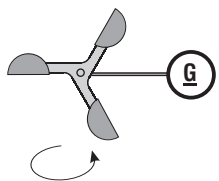
Electrical data		
		
Measuring system	Magnetic	Tacho-Generator
Article number	2028S02-...	2028S22-...
IP code (casing)	IP66	IP64
Electrical connection	plug or cable	plug or cable
Measuring range	0 - 40 m/s (up to max. 50 m/s on request)	0 - 40 m/s (up to max. 50 m/s on request)
Current output	4 - 20 mA, $R_i \leq 600 \Omega$	
Voltage output	0 - 10 V, $R_i \geq 10 k\Omega$	
Digital output	CANopen	
Pulse output	customized	
DC generator		0 - 3,4 V at 0 - 40 m/s at $R_i = 500 \Omega$
Supply	18 - 33 V DC	
Casing material	aluminium, grey coated	aluminium, grey coated
Cross arms	stainless steel	stainless steel
Heating device	with thermostat for temperatures up to -50°C	with thermostat for temperatures up to -50°C

General data	
Temperature range	-30°C up to +70°C
Weight	0,8 kg (with pendulum 1,2 kg)
Test voltage	500 V, 50 Hz, 1 min
Immunity to interference	EN 61 000-6-3
Transient emissions	EN 61 000-6-2
Shock	50 g, 6 ms
Vibration	4 g Sinus 5 - 100 Hz



Available in ex intrinsically safe version. 

Type designation code Anemometer

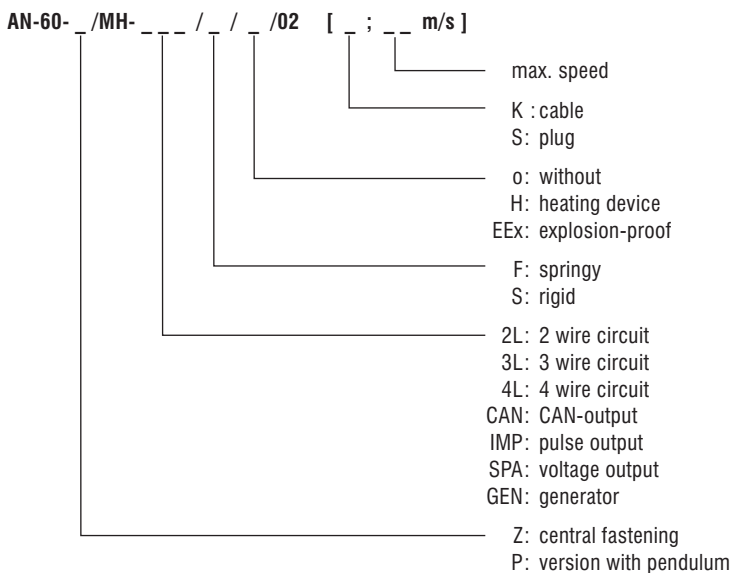

Circuit

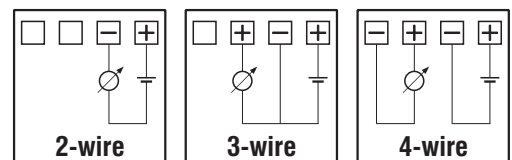

Models

Central fastening (pedestal for vertical post mounting)

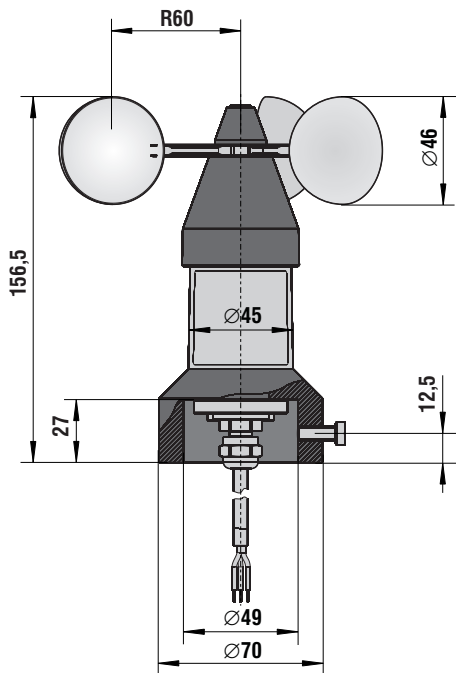

Pendulum (wall bracket)

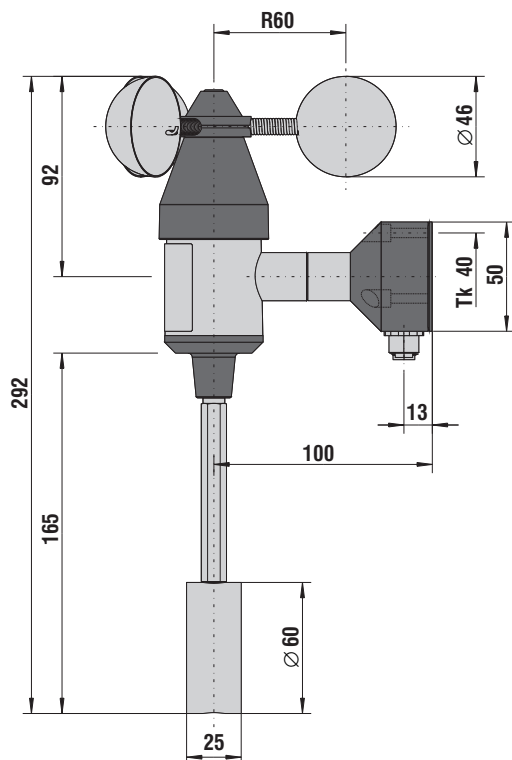

Model types

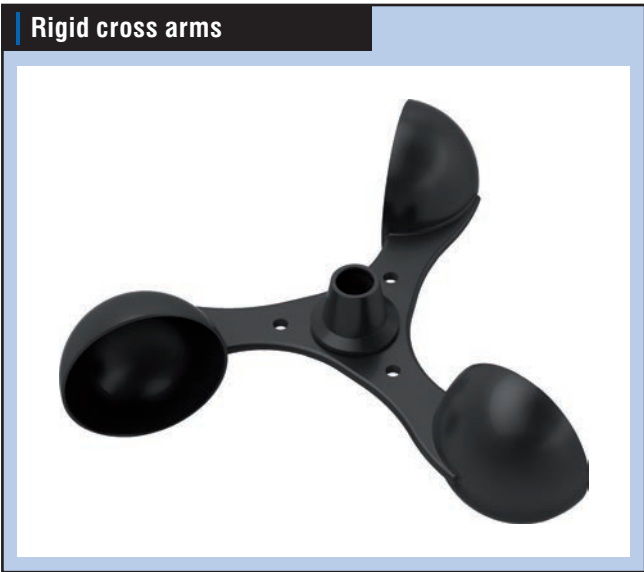

Rigid cross arms

are absolutely rigid and of stainless steel. They are normally used for the wind speed measuring.

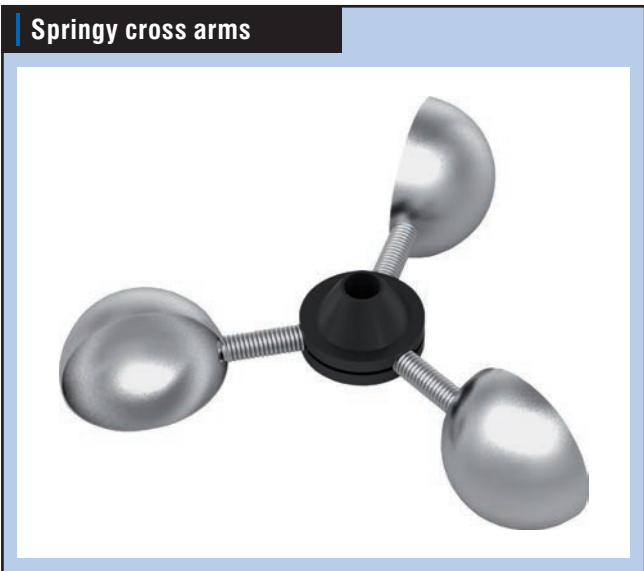

Springy cross arms

Rigid arms are replaced by springy cross arms in order to avoid mechanical stress mainly occurs in cranes and excavators.

Springy cross arms are mostly used in anemometers with pendulum orientation.

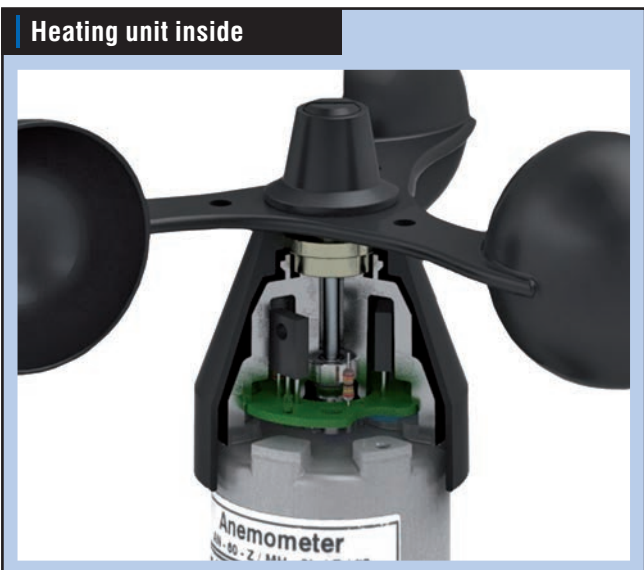

Heating unit inside the cross arms bearing

An electronic controlled heating unit activated at +5 degrees is concerned. Available for both anemometer designs. The heating with a power of 5 W is either fed by supply voltage or separately according to customer request.

Accessories

Indicator	Type GA-dig-1Sez/56
Model type	Flush mounting casing
Front frame	72 mm x 72 mm
Actual value display	LED bar graph, green
Scale	0 - 40 m/s, 2 : 2 m/s
Input	4 - 20 mA, Ri 50 Ω
Supply	18 - 33 V DC, < 200 mA
Limit display	LED, edt
Limit value output	Floating reversing switch max. 30 V, max. 500 mA
Temperature range	-30°C up to +70°C
Test voltage	500 V 50 Hz 1 min.
Weight	0,5 kg

Switchgear	Type R-V-2K-02/K16
Model type	Casing for installation on DIN rails
Input	4 - 20 mA, Ri 50 Ω
Supply	18 - 33 V DC, < 100 mA
Output	2 normally closed or normally open contacts max. 30 V, max. 500 mA
Switching point preselection	Separately by trimming potentiometers between 0 and 100% each
Temperature range	-30°C up to +70°C
Test voltage	500 V 50 Hz 1 min.
Weight	0,3 kg

Models

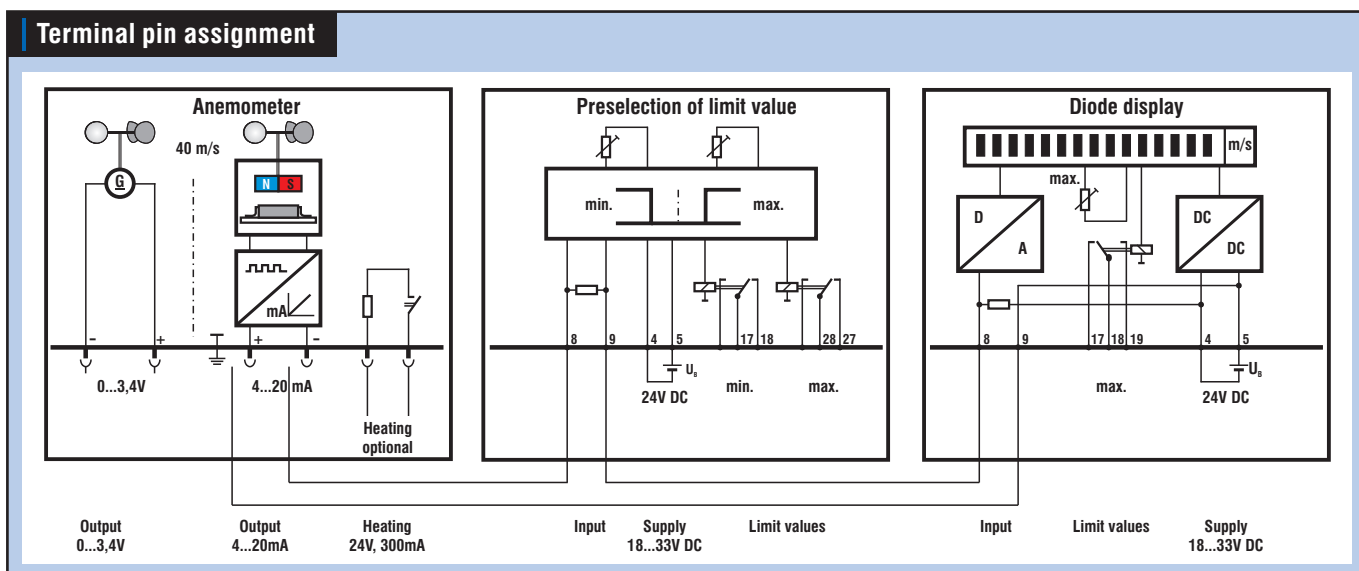
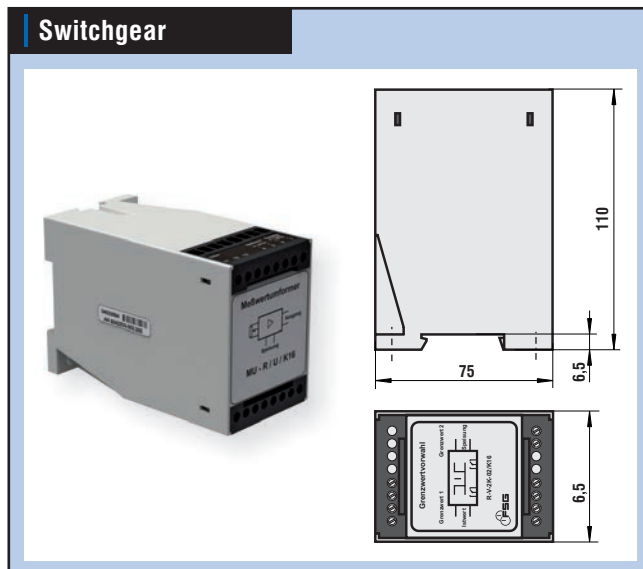
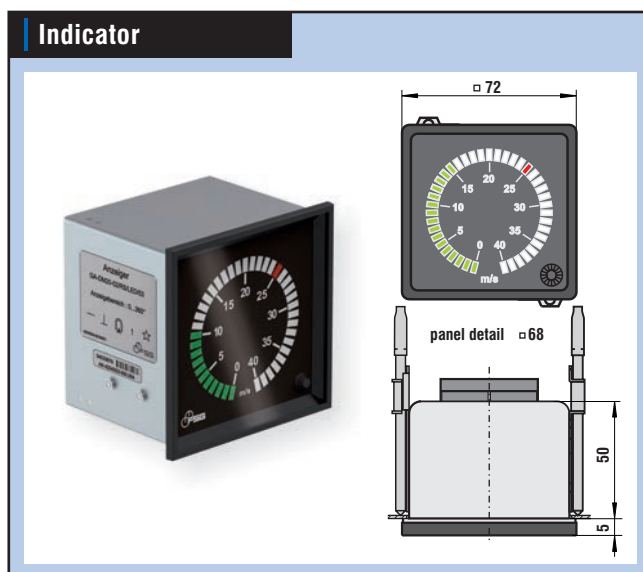



Headquarter in Berlin

Berlin

Fernsteuergeräte

Kurt Oelsch GmbH

Jahnstraße 68 + 70

D-12347 Berlin

Phone +49 (0 30) 62 91 - 1

Fax +49 (0 30) 62 91 - 277



Factory in Kablow

Kablow

FSG Fernsteuergeräte

Meß- und Regeltechnik GmbH

OT Kablow

Mühlenweg 2-3

D-15712 Königs Wusterhausen

Phone +49 (0 33 75) 269 - 0

Fax +49 (0 33 75) 269 - 277



Factory in Heppenheim

Heppenheim

Fernsteuergeräte

Kurt Oelsch GmbH & Co.KG

Weierhausstraße 10

D-64646 Heppenheim

Phone +49 (0 62 52) 99 50 - 0

Fax +49 (0 62 52) 72 05 - 3



info@fernsteuergeraete.de
www.fernsteuergeraete.de