

Universal Instrumentation Amplifier for strain gage, potentiometric, DC/DC and incremental sensors

MODEL 9250 NEW

Preliminary data sheet

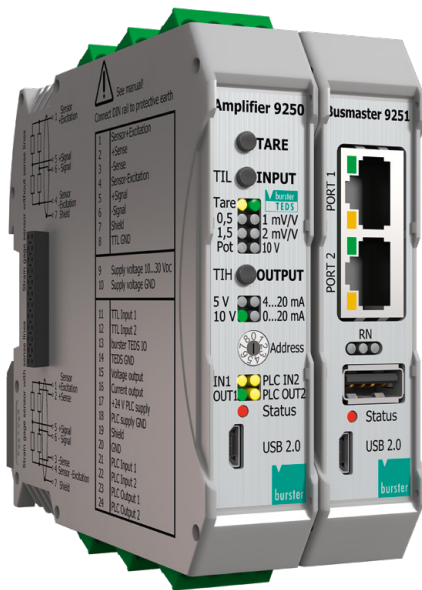

Highlights

- Ultra-fast pushbutton configuration
- Non-linearity < 0,005 % F.S.
- Outputs ± 10 V, ± 5 V and 0 (4) - 20 mA
- 6 wire technique
- Automatic sensor recognition due to burster TEDS
- Adjustable cut-off frequencies
- Versatile configuration using DigiVision PC software via USB port

Options

- Digital I/O to the PLC
- Increased sampling rate up to 14.4 kHz
- Interface for the connection to bus controller 9251
- TTL input for incremental sensors

Applications

- All areas of mechanical engineering
- Assembly and joining equipment
- Hydraulic presses
- Measurement of cable strengths

Product description

The new 9250/9251 amplifier generation unites all the features that make modern measurement data acquisition actually possible for the first time. Network-compatible, high-precision, user-friendly, smart and versatile: the combined system of amplifier module and bus controller can be integrated into any existing setup. The amplifier 9250 takes signals exactly to the point where they can be combined, monitored and linked efficiently to other data. The fieldbus interfaces give you flexibility, speed and perfect connections, and save you time, money and other resources when integrating your measurement setup with existing systems. Automatic sensor recognition due to burster TEDS lets you play absolutely safe, protecting you from setting incorrect parameters.

The broad supply voltage range permits operation on standard power supplies used in switch gear cabinets. A highly accurate precision amplifier performs the amplification of the sensor signal being applied. The latest microprocessor technology made a 24 bit AD conversion with high accuracy possible. The sensor excitation is performed by the amplifier module itself so that no additional voltage source is required. It can also be set in steps of 2.5 V, 5 V, 10 V using configuration software DigiVision. The maximum feed current of 40 mA permits parallel connection of several strain gages sensors, e.g. for the addition of measurement variables. Measurement errors brought about by varying line lengths or due to temperature fluctuations effecting the sensor cable are avoided by having probe lines measuring the actual feed voltage directly on site at the sensor itself (6 wire technology). The cut-off frequency of the amplifier can be switched between 10 Hz and 1 kHz.



Amplifier module 9250



Bus controller 9251



8 measurement channels

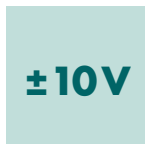

Technical Data

Connectable sensors		
Strain gage full bridge		
Excitation voltage		2.5 / 5 / 10 V, configurable, short-circuit proof
Connection technology		4 or 6 wire, automatic recognition
Excitation current		approx. 40 mA
Input impedance		1 GOhm
Measuring ranges		±15 mV, ±30 mV, ±300 mV
Potentiometer		
Excitation voltage		5 V
Excitation current		max. 40 mA
Resistance		>200 Ohm
Input impedance		1 GOhm
Voltage metering		
Measuring range		±10 V
Input impedance		1 GOhm
TTL inputs		
Level		TTL, 5V, approx. 3 mA, galvanically isolated from amplifier
Counter depth		32-bit, 4 counter increments
Cut-off frequency		2 MHz
Analog outputs		
Voltage outputs		±5 V or ±10 V
Internal resistance		100 Ohm
Current output		0 ... 20 mA or 4 ... 20 mA, Load 50 up to 500 Ohm
Filter		without, 4 Hz - 700 Hz in discrete bands
PLC IO		
Two inputs		PLC level DIN 61131
Function		Tare, peak-value buffer reset, limits reset, HOLD, counter reset
Response time		20 ms
Two outputs		PLC level DIN 61131, p-switched, max. 500 mA, 24 V external supply necessary, Inputs and outputs galvanically isolated from amplifier, Function configurable via USB
Function		Above limit, below limit, window modus
Response time		<0.5 ms
Housing		
Material		polyamides, metal housing inside
Dimensions		115 x 110 x 22.5 mm ³
Weight		approx. 210 g
Protection class		IP20
Connections		Screw clamps, up to 2.5 mm ²

Technical Data

General data	
Supply voltage	11 ... 30 V DC, Galvanic separation, overvoltage and pole protection
Capacity	approx. 3 W
Sensor recognition	burster TEDS
Operating temperature range	0 ... +60 °C
Storage temperature range	-25°C ... +70 °C
Humidity	0 ... 70 % non condensing
Installation	grounded mounting rail 35 mm to DIN EN 50022
Electrical isolation	Instrumentation amplifier, TTL inputs, PLC IO, supply voltage
Error limit	±0.03 % F.S.
AD conversion	24-Bit
DA conversion	16-Bit
Max. measuring rate	14400 (option), 1200 standard
Non-linearity	< 0.005 % F.S.
Temperature coefficient Gain	< 15 ppm F.S. / K
Input zero drift	< 0.1 µV / K
Common mode rejection (CMRR)	140 dB (Bei DC)
Interfaces	Micro USB for configuration
Ripple & Noise at voltage output	approx. 5 mVss at 1200 meas./s
Other	Teach-in via button, tare function via button, I/O configuration via button or USB

Block diagram

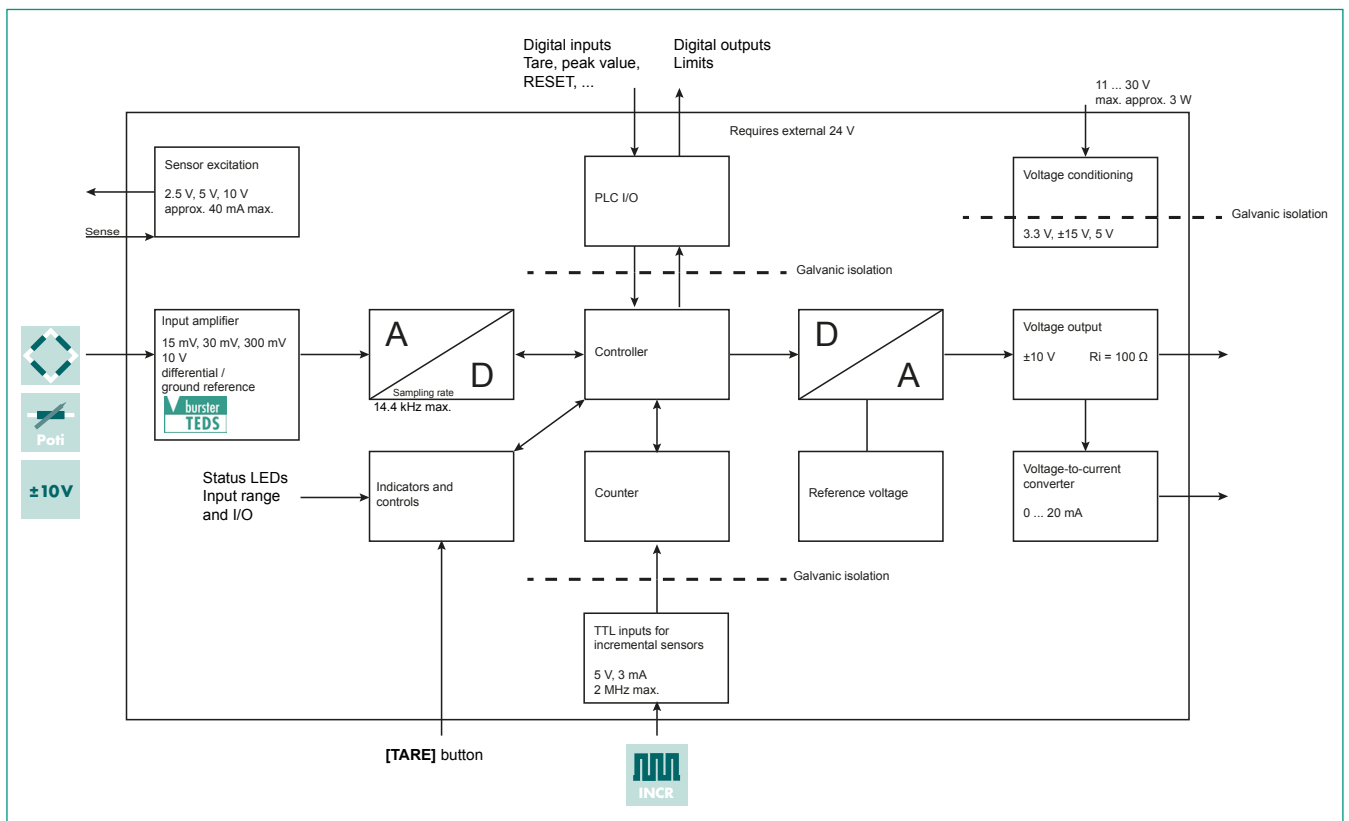

Pin assignment

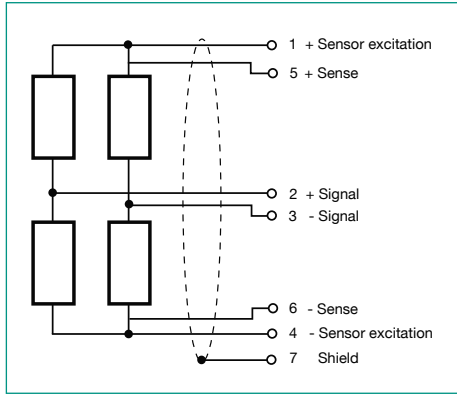

Strain gage 6 wire

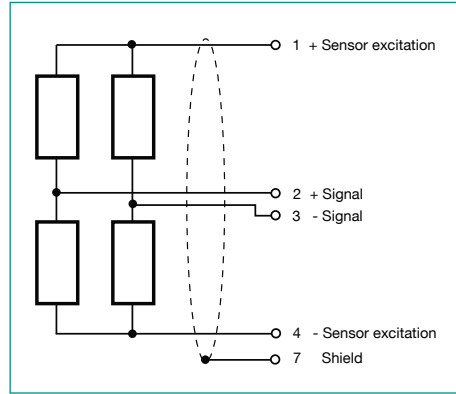

Strain gage 4 wire

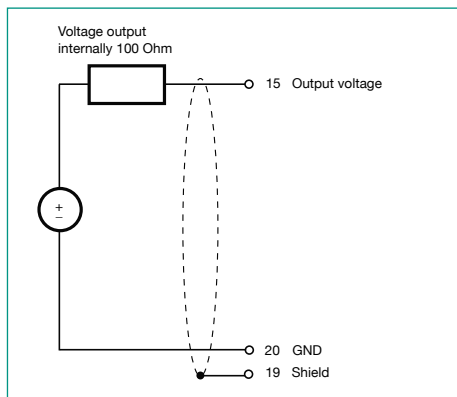

Output Voltage

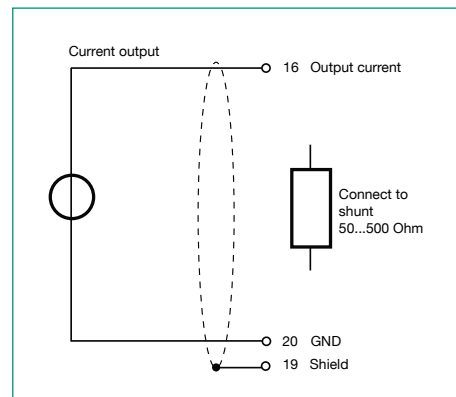

Output current

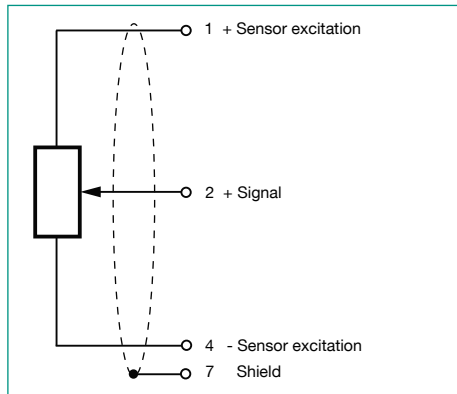

Poti

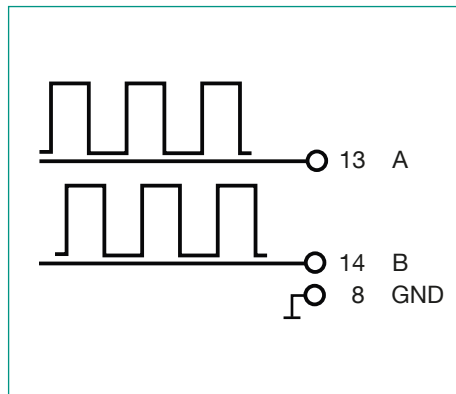

Counter

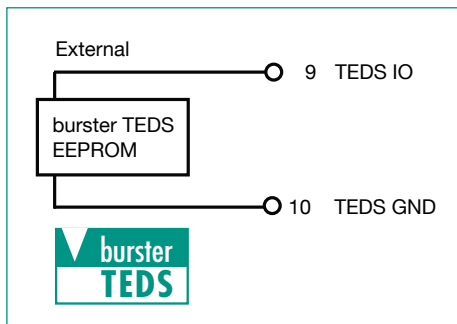

TEDS

DigiVision PC Software

The amplifier module model 9250 is used wherever measurement signals from strain gage, potentiometric sensors or DC/DC sensors have to be converted into standard signals. Simply by mounting on conventional DIN-mount rails, it is possible to position the amplifier module on location, in the proximity of the sensor.

- Convenient device configuration via front-panel USB port
- Automatic recognition of amplifier modules in DigiVision
- Manage a range of parameter sets
- Backup facility for storing settings
- Choice of output parameter (current or voltage)
- Bus controller configuration via USB
- Manual configuration of calibration data in the module

Ultra-fast pushbutton configuration

- ▶ Select input
- ▶ Select output
- ▶ Get started

Accessories

Order Code		
9900-K358		USB cable for configuration
9250-Z001		1 set of terminals (included in scope of delivery)

Calibration for instrumentation amplifiers

Standard factory calibration certificate for instrumentation amplifiers (WKS)		
Optionally available		Our standard factory calibration certificate includes 11 measurement points, starting at zero, spread evenly in 20% steps over a measuring range.
Special factory calibration certificate for instrumentation amplifiers (WKS)		
On request		We are happy to calibrate instrumentation amplifiers to the customer's specification.
German-accredited DAkkS calibration certificate for instrumentation amplifiers (DKD)		
Optionally available		Our DAkkS-certified calibration laboratory provides calibration certificates. The calibration certificate includes 21 measurement points, starting at zero, spread evenly in 10% steps over a measuring range.

Calibration for measurement chains

Standard factory calibration certificate for measurement chains (WKS)		
Optionally available		Our standard factory calibration certificate includes 11 measurement points, starting at zero, spread evenly in 20% steps over the full measuring range, for increasing and decreasing load under the same installation conditions. Factory calibrations can be performed in the compression and/or tension direction depending on the sensor type.
Special factory calibration certificate for measurement chains (WKS)		
On request		We are happy to calibrate sensors and measurement chains to the customer's specification.
German-accredited DAkkS calibration certificate for measurement chains (DKD)		
Optionally available		Our DAkkS-certified calibration laboratory provides calibration certificates to DIN EN ISO 376. The calibration certificate includes 21 measurement points, starting at zero, spread evenly in 10% steps over the measuring range, for increasing and decreasing load under various installation conditions. DAkkS calibrations can be performed in the compression and/or tension direction depending on the sensor type.

Order Code

						Standard					
						0	0	0	0	0	0
9	2	5	0	-	V						
Housing version											
■ IP20 mounting rail housing						0					
Input signal											
■ Strain gage, poti and normalized signal						0					
■ Strain gage, poti, normalized signal and TTL						1					
Output signal											
■ Analog output ±10 V and 0 (4) ... 20 mA						0					
■ without (only possible with bus interface)						1					
PLC interface limit values											
■ without								0			
■ Digital I/O (2 inputs and 3 outputs)								1			
Multi-channel operation with bus controller											
■ without bus interface									0		
■ with bus interface for bus controller									1		
Cut-off frequency											
■ Sampling up to 1200 Hz										0	
■ Sampling up to max. 14,4 kHz											1